



Trimline Zircon 1024

INSTALLATION INSTRUCTION



CONTENTS

| | | |
|------------|--|----|
| 1 | GENERAL INSTRUCTIONS | 3 |
| 2 | PLACING THE APPLIANCE..... | 3 |
| 2.1 | Preparation and installation | 3 |
| 2.2 | Connection to the gas supply pipes | 3 |
| 3 | INSTALLATION OF THE CERAMIC WOOD SET AND DISPERSION MEDIUM..... | 6 |
| 4 | TECHNICAL DETAILS MAXITROL GV60..... | 8 |
| 5 | INSTRUCTIONS FOR MAXITROL GV60 | 10 |
| 6 | GAS-TECHNICAL SPECIFICATIONS..... | 11 |
| 7 | CONCENTRIC PATHWAYS..... | 13 |
| 8 | CONCENTRIC FLUE SYSTEM | 14 |
| 8.1 | Components of the concentric flue system | 14 |
| 8.2 | Construction of concentric flue system | 14 |
| 8.3 | Installation instructions regarding existing flues..... | 14 |
| 8.4 | Parts | 15 |
| 8.5 | Installation..... | 15 |
| 9 | PASS-THROUGH POSITIONS AND FUNCTION CORRECTLY..... | 16 |
| 10 | CLEANING AND MAINTENANCE..... | 17 |
| 11 | QUICK REFERENCE GUIDE FOR FAULTSSEARCH FOR ENCLOSED APPLIANCES USING MAXITROL GV60 GASCONTROL | 19 |
| Appendix 1 | DIMENSIONAL DRAWINGS..... | 21 |
| Appendix 2 | CONSTRUCTION DIAGRAM DOUBLE-WALL CONCENTRIC | 22 |

thermoCet International B.V.
Laagerfseweg 27
3931 PC Woudenberg
The Netherlands
www.trimlinefires.com



Modifications and printerrors are reserved.

thermoCet International BV is not responsible for any
(consequential) damage due to incorrect installation.

V230921



1 GENERAL INSTRUCTIONS

NOTE

The installation may only be carried out by an authorised person.

- The appliance must be installed, connected, inspected and serviced as a closed appliance by a qualified fitter, according to local standards and regulations.
- The flue tube system and the outlets in the outer wall or roof face must also meet the requirements outlined in the applicable local standards and regulations.
- The temperature of the walls near the side and back of the appliance may not exceed the ambient temperature by 60 K or more. For example, ambient temperature 20 °C, maximum increase of 60 K gives a maximum temperature of 80 °C.
- The appliance has been approved in combination with the concentric flue system THC/Holetherm in accordance with European CE standards for gas appliances, and may therefore only be applied with this system.
- The appliance needs to be inspected by the fitter for local gas distribution (gas type and gas pressure) as indicated on the identification plate.
- The instructions are only applicable if the relevant country code is stated on the appliance.
- There will be air in the gas pipes when the appliance is first used. The gas supply pipes therefore need to be vented first. The glass panel must not be in place when venting and igniting the first time.

- Ignite the appliance according to the user manual and check the flame is burning evenly. After the appliance has been used for the first time, any deposits resulting from curing must be removed from the glass panel using a glass cleaner made specifically for fireplaces.

Distance to flammable materials

Maintain the following minimum distances from combustible materials: front 1000mm, side 500mm, top 1200mm to curtains, fabrics and/or combustible material. Maintain a minimum distance of 50mm from the back wall.

Distance to non-flammable materials

The appliance needs to be placed a minimum distance of 25mm from the wall.

WARNING

- Gas fires become hot when in use. After installation of the appliance, the glass panel surface is considered to be an active zone. The glass panel surface can become very hot.
- Therefore, you should take care by, for example, keeping children and those requiring help away from the immediate vicinity of burning fires. Gas fires must not be placed on or against flammable materials.

2 PLACING THE APPLIANCE

NOTE

Before installing the appliance, please read Chapter 4 *Removing and installing the glass panel*, 10 *Concentric pathways*, 11 *Concentric flue system* and APPENDIX 2.

2.1 Preparation and installation

- Check the packaging for damage. Remove the packaging and check the contents are intact and complete. Report damage and defects to the supplier immediately.
- The packaging contains the following components:
 - Appliance
 - Remote control
 - Ceramic wood set
 - Bag of glow wool
 - Dispersion medium
 - Restrictor
 - 4 x AA battery
 - 2 x AA battery
 - Suction cup(s)
 - Installation instruction
 - User Manual

NOTE

Do not start the installation until you have read and understood the installation instructions.

- Do not place the appliance on its side.
- Place the appliance on a stable surface. Remove the glass panel (see Paragraph *Remove the glass panel on page 4*) so you can take out the packaged parts. Check it for damage and defects.

2.2 Connection to the gas supply pipes

- You can determine where the gas supply pipes will be placed, dependent on the layout. Ensure control equipment is not twisted during installation and there is no excessive tension. Accessibility of various connection points in relation to components needs to be maintained. After installation, check the connections are gas-tight. Use a 3/8" gas tap with a connector. Also ensure the gas supply pipe is free from dirt or sand. To prevent damage to the gas control equipment, the gas connection must be isolated from the electrical power.
- Ignite the appliance for the first time without a glass panel. Check all the gas connections for leaks again. You can then switch the appliance off and put the ceramic wood set in place (see Chapter 3 *Installation of the ceramic wood set and dispersion medium*).

Put the appliance in its place taking into account the distances from (non-)combustible materials described in Chapter 1 *General instructions*.

The concentric flue system can then be fitted, see Chapter 7 *Concentric pathways* and 8 *Concentric flue system*.

Remove the glass panel

- Remove the cover frame. Slide the cover frame upwards and remove the cover frame from the appliance forwards.
① ① ② ①
- The glass panel is clamped in place with a glass panel frame, the 4 mounting screws are now visible. ② ②

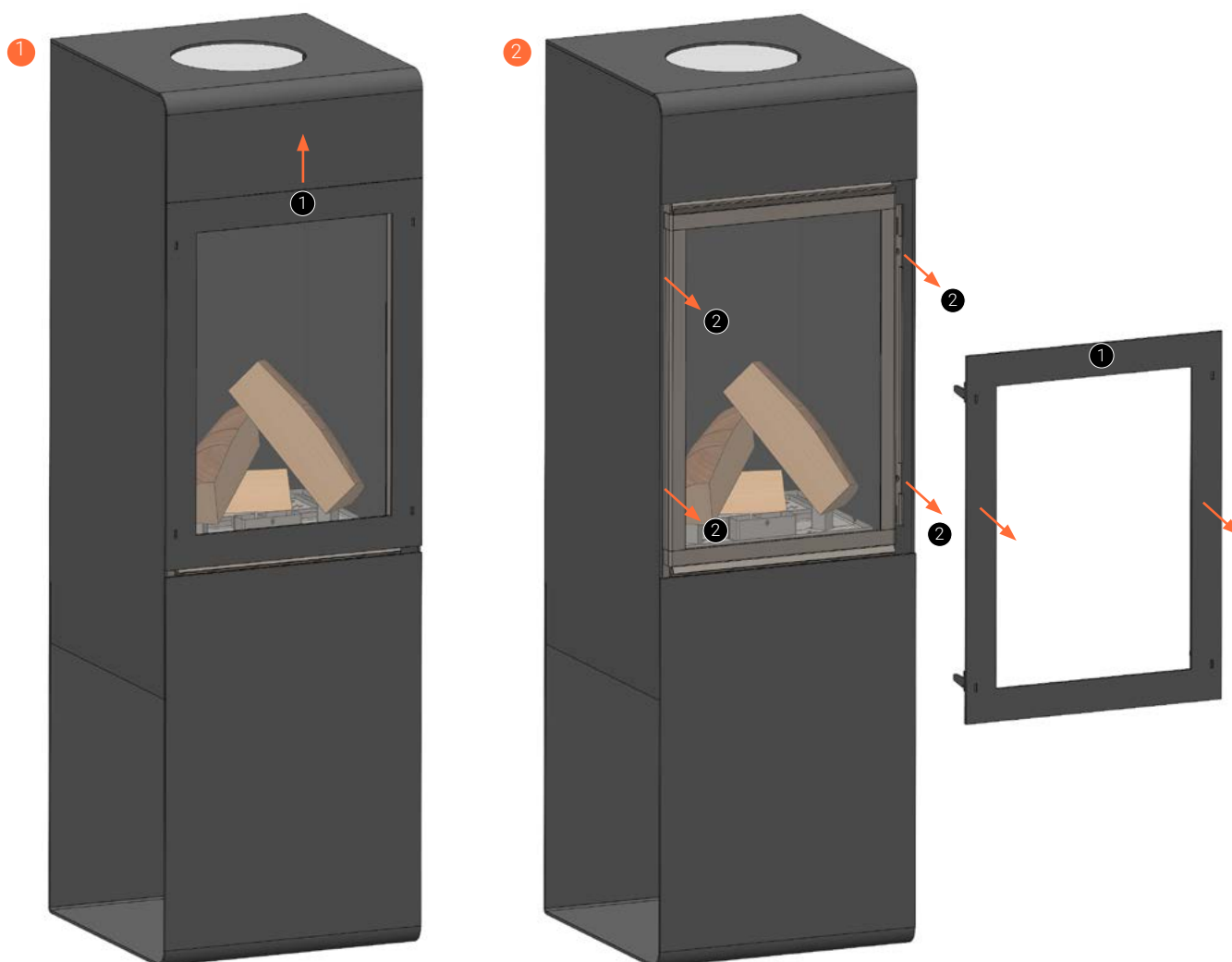

- Remove these 4 screws and remove the glass panel frame.

3 3

NOTE

Hold the glass panel to make sure it cannot fall forward.

- The glass panel can now be removed. 4 4
- Place the glass panel in a safe place so that it does not fall and/or become damaged.

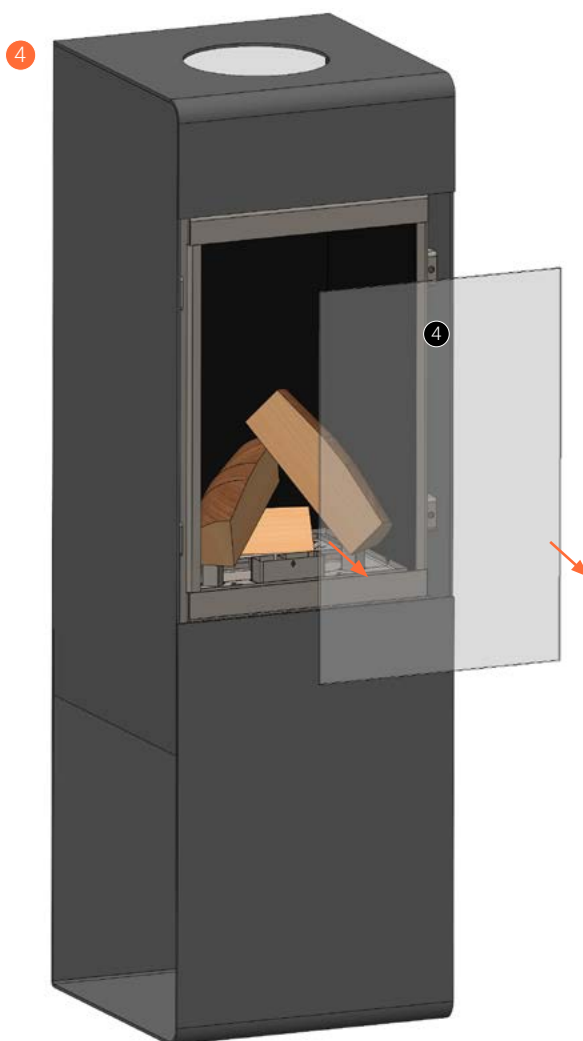

Refitting the glass panel

Refitting the glass panel is done in the reverse order.

3 INSTALLATION OF THE CERAMIC WOOD SET AND DISPERSION MEDIUM

First, distribute the glow granules evenly over the central burner. **3**

NOTE

- Ensure the granules are kept away from the pilot flame so they do not affect it.
- Make sure stone chips do not get in front of the pilot flame or to the rear of the burner mesh.

The glow wool can now be placed on the central burner that has granules distributed over it, a tuft here and there. Then evenly distribute the stone chips around the burner mesh. **4**

Place the central log **5 6 A** correctly on the central burner. Ensure it is correctly put in place.

Place logs marked with **7 8 F** left and **G** right on the 2 standing burners. Pay attention to the correct placement of the logs left and right and ensure there is no tension.

Check the fuel openings at the front and rear remain open so gas can flow freely.

Place the charred log trunk **9 B** in front of the pilot flame. Ensure it is correctly put in place.

Handle the logs carefully, the ceramic material is very fragile (for example, if dropped or bumped). Do this as accurately as possible; incorrect placement of the logs can negatively influence the flame and cause soot formation.

Before refitting the glass panel, check whether the restrictor and/or baffle plate must be placed. Please refer to Chapter 7 Concentric pathways.

Ignite the appliance, check the pilot flame and burners light easily and that the flames flow evenly along the logs. If this is not the case, check or adjust the position of the logs.



Left standing burner Central burner Right standing burner

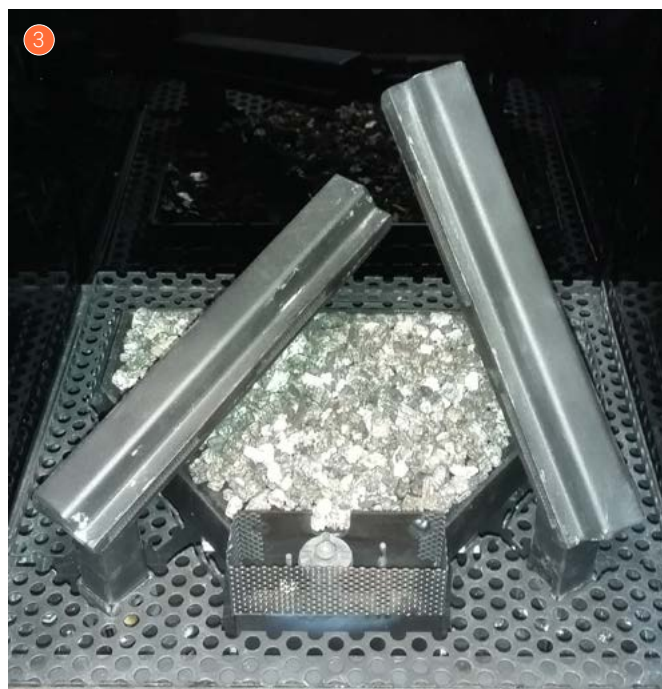
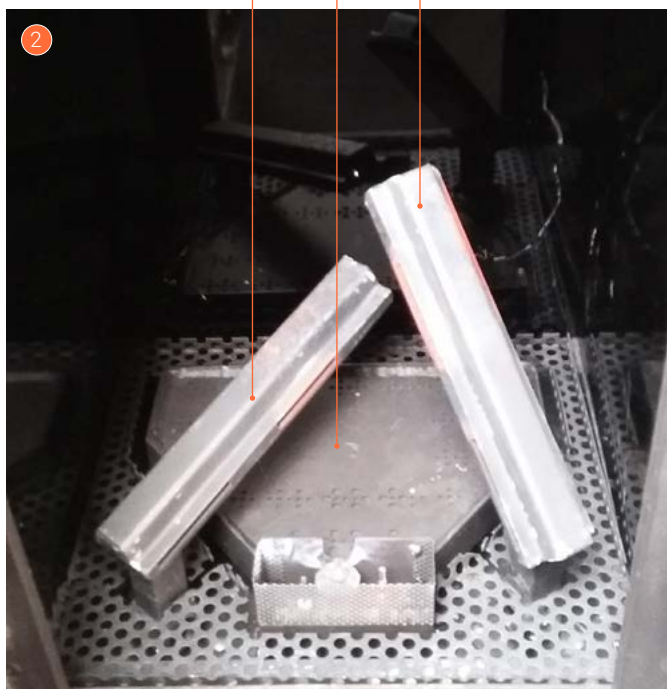

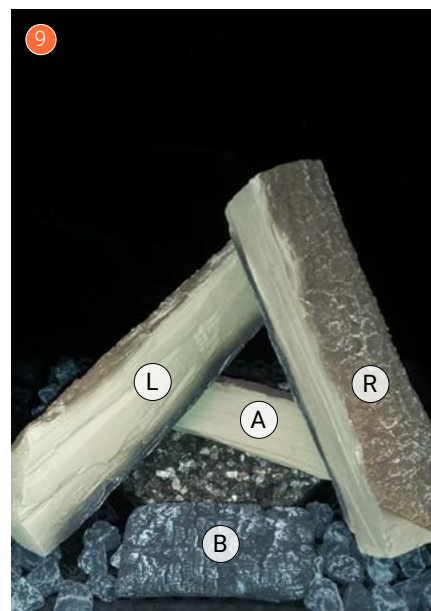
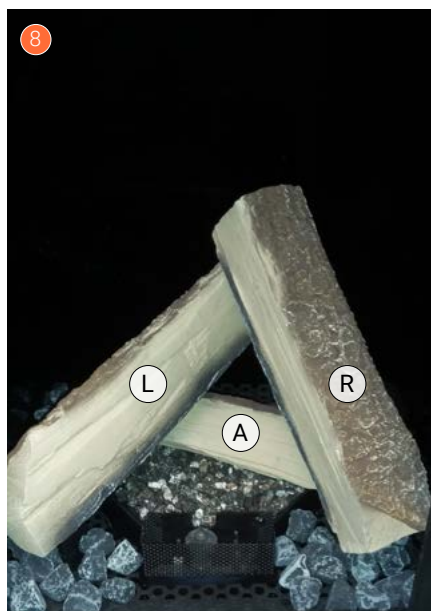
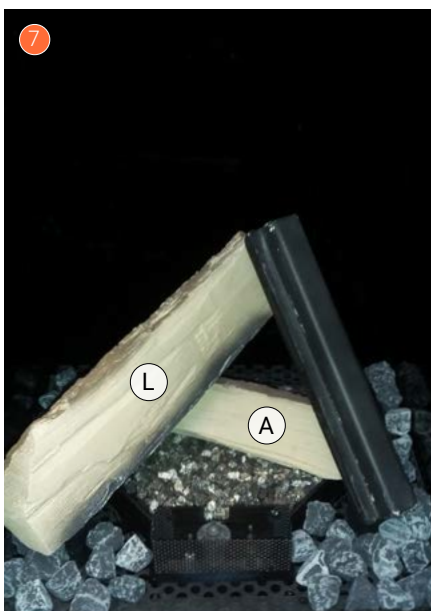

Restrictor and baffle plate 10

The restrictor and/or baffle plate can be mounted inside the appliance, at the location of the flue gas duct.

Chapter 7 *Concentric pathways* contains a table describing if a baffle plate and/or restrictor must be fitted. This is important to ensure the appliance works correctly. The baffle plate is fitted as standard, optional the restrictor can be mounted. Remove baffle plate 2 by loosening the 2 screws on the left and right and slide the baffle plate forward. Fit restrictor 1 and/or the baffle plate in the appliance, if required.

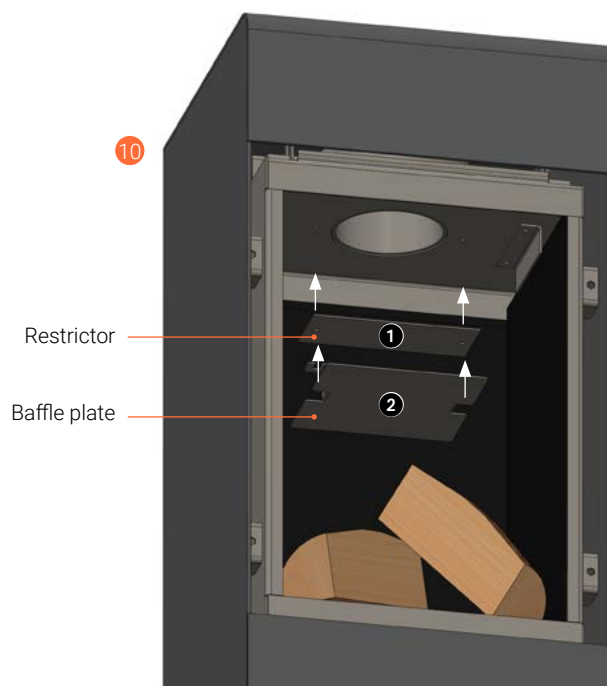

4 TECHNICAL DETAILS MAXITROL GV60

| | |
|--|--|
| Gas valve type | Maxitrol GV60 |
| Automatic ignition control type | B6R-R8P (Wifi Ready) |
| Ignition | Remote control operation and piezo ignition |
| Gas connection | 3/8" (External) ① = Gas inlet ② = Gas outlet ③ = Thermocouple connection ④ = Pilot burner connection |
| Appliance category | C11-C31-C91 |
| Pilot flame | SIT 3 flames |
| Combustion gas outlet and combustion air inlet | Concentric: Ø100/Ø150mm |

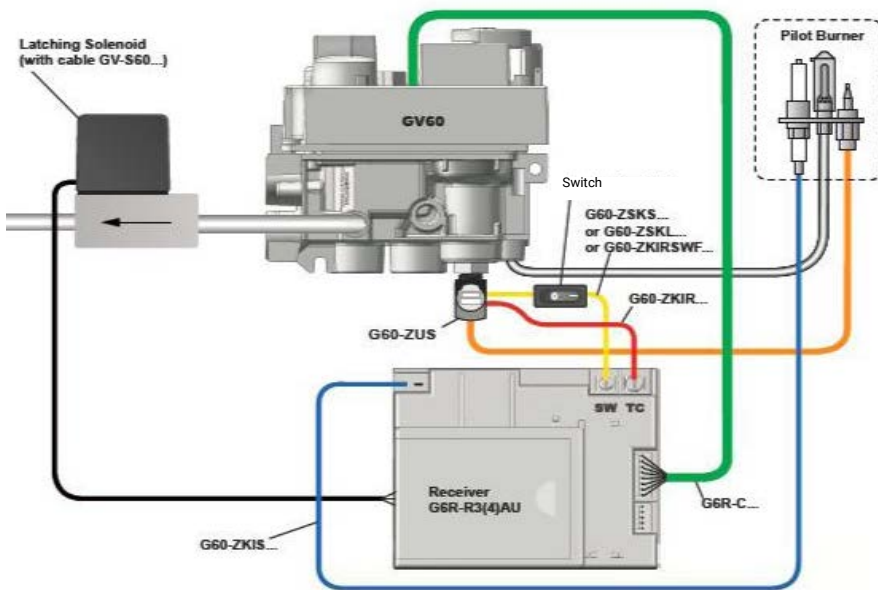
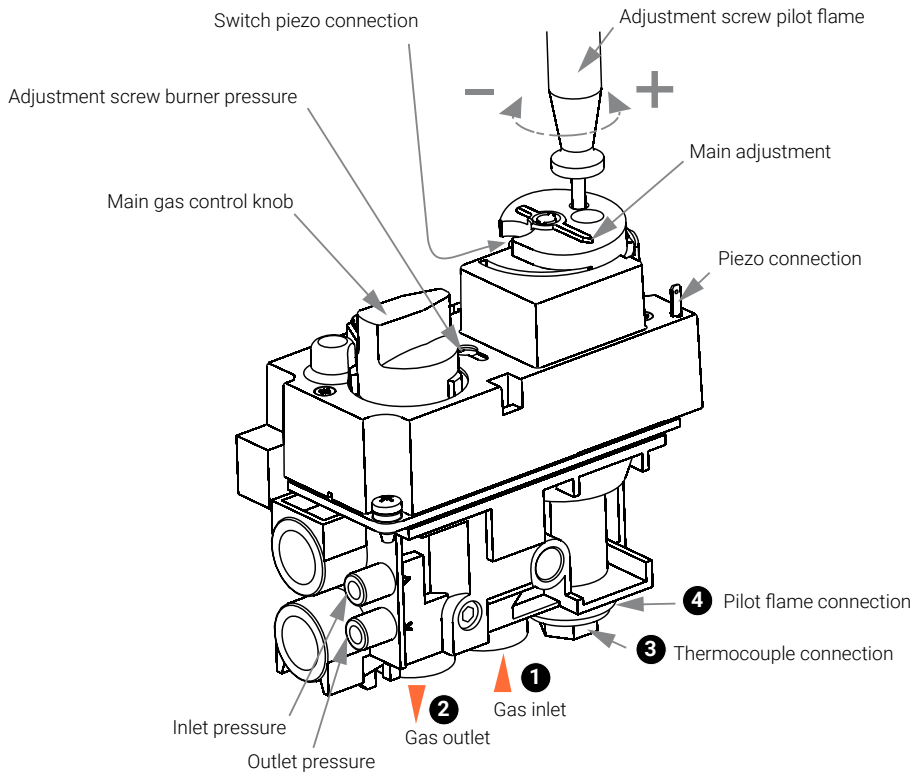

Schematic diagram.

⚠ WARNING
Sealed parts must not be adjusted.

1

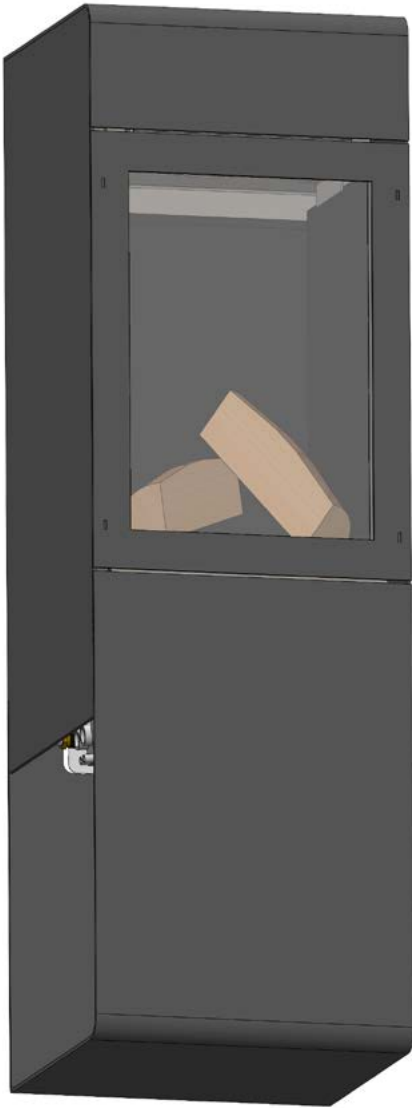

2



3

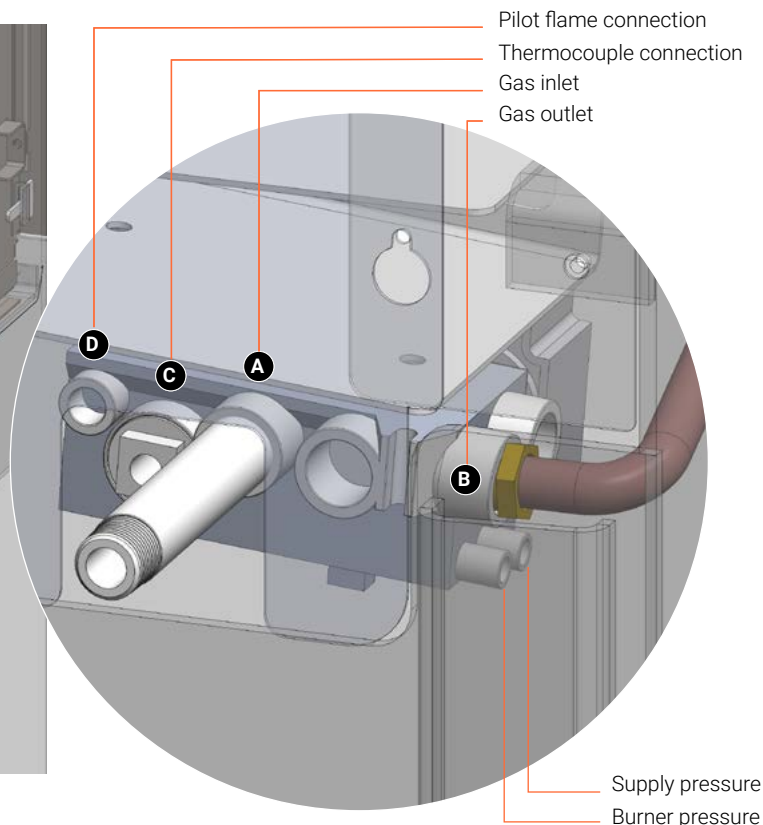
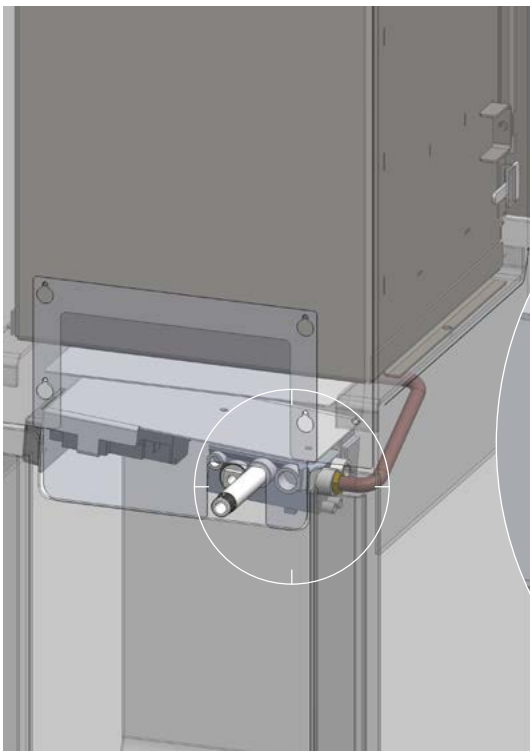

5 INSTRUCTIONS FOR MAXITROL GV60

WARNING

- Ensure the fuel supplied to the appliance is clean and free from particles and moisture.
- The appliance must not be turned on if the glass pane(s) is not present and/or is broken.

Before a gas supply pipe (new or existing) is connected to the main gas pipe at the gas meter and to the gas valve of the appliance, clean and dry compressed air needs to have been blown through it. Copper and aluminium pilot flame pipes that have been cut must be deburred and blown clean before they are connected.

Heat, moisture and dust are a threat to all electronic components

Protect the electronic gas control until all construction, plastering and paintwork has been completed. If you cannot avoid this work, then protect the control against dirt and moisture penetration by covering it with plastic film for instance.

WARNING

- Electronic components become permanently faulty when they are exposed to temperatures higher than 60°C. Normal AA batteries will crack open at temperatures >54°C and the battery contents will damage the electronic switches below. Batteries have the longest life span at <25°C.
- Only install the gas valve and receiver as pre-installed at the factory.
- Remember that components may have to be replaced or that repairs may have to be performed at a later date. This may prove to be more difficult if the control is installed in a different way to how we have described in instructions

Only insert the batteries after the receiver, gas valve and pilot flame have been wired.

Premature connection to the power source can damage the electronics.

Ensure the ignition cable is not near the antenna wire and that they do not cross each other.

The high voltage released during ignition may damage the sensitive receiver circuit of the antenna. This could mean the appliance becomes less responsive or totally unresponsive to commands from the handset.

NOTE

- Do not tighten the contact breaker and the thermocouple connection too tightly on the gas valve.
- It is sufficient to tighten by hand and add a half a turn with an open-end spanner. Tightening too much will break the connection to the magnetic coil below and/or the insulation around the aluminium contact pin in the contact breaker. This may cause the magnetic coil to not open the gas supply to the pilot flame and prevent the appliance from functioning.

Prevent leakage of ignition spark to parts of the installation other than the ignition rod on the pilot flame. Ensure the ignition cable is not in contact with the body or other metal parts. If a cable extension is used, ensure the connections have additional silicone insulation.

The receiver and the control units on the gas valve should be switched on to ensure automatic start-up via the remote control. The oval disc on the gas valve should be turned to the **ON** position. The **I/O** switch should be set to **I**. The ignition cable should be connected to the **SPARK** connection point on the receiver.

The system's thermostat sensor is located inside the remote control. The remote control operates best at a distance of 2 or 3 metres away from the appliance. Although communication occurs via shortwave radio signals, it is recommended that you place the remote control in the line of sight of the gas appliance, in a place where the user wishes to experience a pleasant temperature. Do not place the manual transmitter in direct sunlight or other warm locations. The thermostat measures the temperature and, accordingly, regulates the flame size of the gas appliance.

NOTE

- Sealed parts must not be adjusted, to do so would void the warranty.
- A waiting time of 5 minutes between each start attempt must be observed.
- Remove batteries not with a metal tool. Removing batteries with a metal object can permanently damage the electronic control.

6 GAS-TECHNICAL SPECIFICATIONS

| Type of indication(s) | | 1120 - Free Standing | | | |
|--|-------------------|---|----------------------------|---|----------------------------|
| Appliance type | | C11, C31, C91 closed combustion | | | |
| Concentric extraction system | | Holetherm CC 100-150 | | | |
| Gas type | | G25,3 | G20/25 | G20 | G20↔25 |
| Supply pressure in mbar | | 25 | 20 | 20 | 20↔25 |
| Country | | NL | DE | AT/CH/CZ/DE/DK/EE/ES/FI/GB/GR/HR/IE/IT/LT/LU/LV/NO/PL/PT/RO/SE/SI/SK/TR | BE/FR |
| Category | | I ₂ EK I ₂ (43,46-45,3 MJ/m ³) | I ₂ ELL | I ₂ H/I ₂ E | I ₂ E* |
| Primary air per burner | mm | L=2xØ6 M=3xØ11,5 R=2xØ6 | L=2xØ6 M=3xØ11,5 R=2xØ6 | L=2xØ6 M=3xØ11,5 R=2xØ6 | L=2xØ6 M=3xØ11,5 R=2xØ6 |
| Supply pressure | mbar | 25 | 20 | 20 | 20 |
| Burner pressure - high position | mbar | 19,1 | 19,4 | 15,5 | 15,5 |
| Burner pressure - low position | mbar | 11,1 | 8,9 | 8,7 | 8,7 |
| Injector orifice | Ømm | L=1,05 M=1,1 R=1,05 | L=1,05 M=1,1 R=1,05 | L=1,05 M=1,1 R=1,05 | L=1,05 M=1,1 R=1,05 |
| Pilot flame injector | CODE | 51 | 51 | 51 | 51 |
| Low position orifice | mm | Adjustable | Adjustable | Adjustable | Adjustable |
| Load Hs | kW | 5,0 | 4,8 | 5,1 | 5,1 |
| Load Hi | kW | 4,5 | 4,3 | 4,6 | 4,6 |
| Gas consumption | m ³ /h | 0,535 | 0,532 | 0,490 | 0,490 |
| Nominal power - high position | kW | 3,6 | 3,7 | 3,9 | 3,9 |
| Nominal power - low position | kW | 1,7 | 2,6 | 2,9 | 2,9 |
| NOx Hi EN613 | classe | 4 | 4 | 4 | 4 |
| Efficiency Class EN613 | | 1 | 1 | 1 | 1 |
| Useful return (NCV) system** | | | | | |
| For nominal heat output | % | 83,1 | 85,1 | 83,5 | 83,5 |
| For minimal heat output | % | 77,9 | 76,6 | 79,1 | 79,1 |
| Supplementary electricity consumption | | | | | |
| Nominal | kWh | - | - | - | - |
| Stand-by | kWh | - | - | - | - |
| Energy efficiency*** | | | | | |
| Energy efficiency index (EEI) | % | 83 | 85 | 84 | 84 |
| Energy label | | B | B | B | B |
| NOx Hs | mg/kWh | 107 | 113 | 117 | 117 |
| Heat output type/room temperature control | | | | | |
| Indirect heat functionality | | | | | No |
| Single stage heat output, no room temperature control | | | | | No |
| 2 or more manually-adjustable stages, no control of the room temperature | | | | | No |
| With mechanical control of room temperature by thermostat | | | | | No |
| With electronic control of room temperature | | | | | Yes |
| With electronic control of room temperature plus day-time switch | | | | | Yes |
| With electronic control of room temperature plus week-time switch | | | | | Yes |
| Other control options | | | | | |
| Control of room temperature with presence detection* | | | | | Yes |
| Control of room temperature with open window detection* | | | | | Yes |
| With remote control option | | | | | Yes |

* In combination with home automation

** Shortest system path

*** EU directive 2015-1186/1188



| Type of indication(s) | | Trimline Zircon 1024 | |
|--|-------------------|---|---|
| type | | C11, C31, C91 closed combustion | |
| Concentric extraction system | | Holetherm CC 100-150 | |
| Gas type | | G30/31 | G30 |
| Supply pressure in mbar | | (28-30)-37 | 30/50 |
| Country | | BE/CH/CY/CZ/ES/FR/GB/GR/IE/IT/LT/PT/SI/TR | NL/AT/CH/CY/CZ/DE/DK/EE/FI/GR/HR/HU/IT/LT/NO/PL/RO/SE/SI/TR |
| Category | | I ₃ + | I ₃ B/P |
| Primary air per burner | mm | L=4xØ7,5 M=3xØ16 R=4xØ7,5 | L=4xØ7,5 M=3xØ16 R=4xØ7,5 |
| Supply pressure | mbar | (28-30)-37 | 30/50 Set burner pressure to 50 mbar |
| Burner pressure - high position | mbar | 28,3 | 28,3 |
| Burner pressure - low position | mbar | 13,6 | 13,69 |
| Injector orifice | Ømm | L=0,75 M=0,75 R=0,75 | L=0,75 M=0,75 R=0,75 |
| Pilot lame injector | CODE | 30 | 30 |
| Low position orifice | mm | Adjustable | Adjustable |
| Load Hs | kW | 5,9 | 5,9 |
| Load Hi | kW | 5,4 | 5,4 |
| Gas consumption | m ³ /h | 0,168 | 0,168 |
| Nominal power - high position | kW | 4,3 | 4,3 |
| Nominal power - low position | kW | 2,8 | 2,8 |
| NOx Hi | classe | 5 | 5 |
| Efficiency Class EN613 | | 1 | 1 |
| Useful return (NCV) system** | | | |
| For nominal heat output | % | 79,7 | 79,7 |
| For minimal heat output | % | 74,1 | 74,1 |
| Supplementary electricity consumption | | | |
| Nominal | kWh | 0 | 0 |
| Stand-by | kWh | 0 | 0 |
| Energy efficiency*** | | | |
| Energy efficiency index (EEI) | % | 80 | 74 |
| Energy label | | C | C |
| NOx Hs | mg/kWh | 102 | 102 |
| Heat output type/room temperature control | | | |
| Indirect heat functionality | | | No |
| Single stage heat output, no room temperature control | | | No |
| 2 or more manually-adjustable stages, no control of the room temperature | | | No |
| With mechanical control of room temperature by thermostat | | | No |
| With electronic control of room temperature | | | Yes |
| With electronic control of room temperature plus day-time switch | | | Yes |
| With electronic control of room temperature plus week-time switch | | | Yes |
| Other control options | | | |
| Control of room temperature with presence detection* | | | Yes |
| Control of room temperature with open window detection* | | | Yes |
| With remote control option | | | Yes |

* In combination with home automation

** Shortest system path

*** EU directive 2015-1186/1188

Suitable for biopropane.



7 CONCENTRIC PATHWAYS

Table of concentric pathways

| Pathway | Illustration | X total in metres | | Y total in metres | | Restriction |
|--|--------------|-------------------|------|-------------------|------|--------------------------------------|
| | | Min* | Max* | Min* | Max* | |
| X = vertical and Y = horizontal | | | | | | Trimline Zircon 1024 |
| Indirect façade outlet G20/25/25,3 | A-B | 1 | 3 | 0 | 6,5 | - |
| Indirect façade outlet G30/G31 | A-B | 1 | 3 | 0 | 6,5 | - |
| Roof pass-through without slope | C | 2 | 20 | - | - | From 3 meter |
| Roof pass-through with 45° slope** | D | 3 | 20 | 0 | 4 | From X total - Y > 6 meter: 60/45 mm |
| Roof pass-through with 90° slope*** | E | 3 | 20 | 0 | 2 | From X + X1 - Y > 6 meter: 60/45 mm |

45° Bend: calculation length 1 metres

90° Bend: calculation length 2 metres

* Length including roof or exterior wall outlets. Always adhere to a starting length of 1 metre.

** Ratio vertical : horizontal X + X1 + X2: Y ≥ 2: 1

*** Ratio vertical : horizontal X + X1: Y ≥ 2: 1

Restriction conditions all gas types

| Distance | Baffle plate | Restriction |
|---|-------------------|-------------|
| G20/G25/25.3 Vertical lay out | | |
| 1-6m | Yes height 30mm | 55mm |
| 6-12m | Yes height 30mm | 60mm |
| G30/G31 Vertical lay out | | |
| 1-6m | Yes height 17.5mm | 55mm |
| 6-12m | Yes height 17.5mm | 60mm |
| G20/G25/25.3 horizontal sections up to 6.5 meter including wall ducts | | |
| 1m 90° and 0.5m | Yes height 30mm | 60mm |
| 1m 90° and 6.5m | No | No |
| G30/31 horizontal sections up to 6.5 meter including wall ducts | | |
| 1m 90° and 0.5m | Yes height 17.5mm | 55mm |
| 1m 90° and 6.5m | No | No |

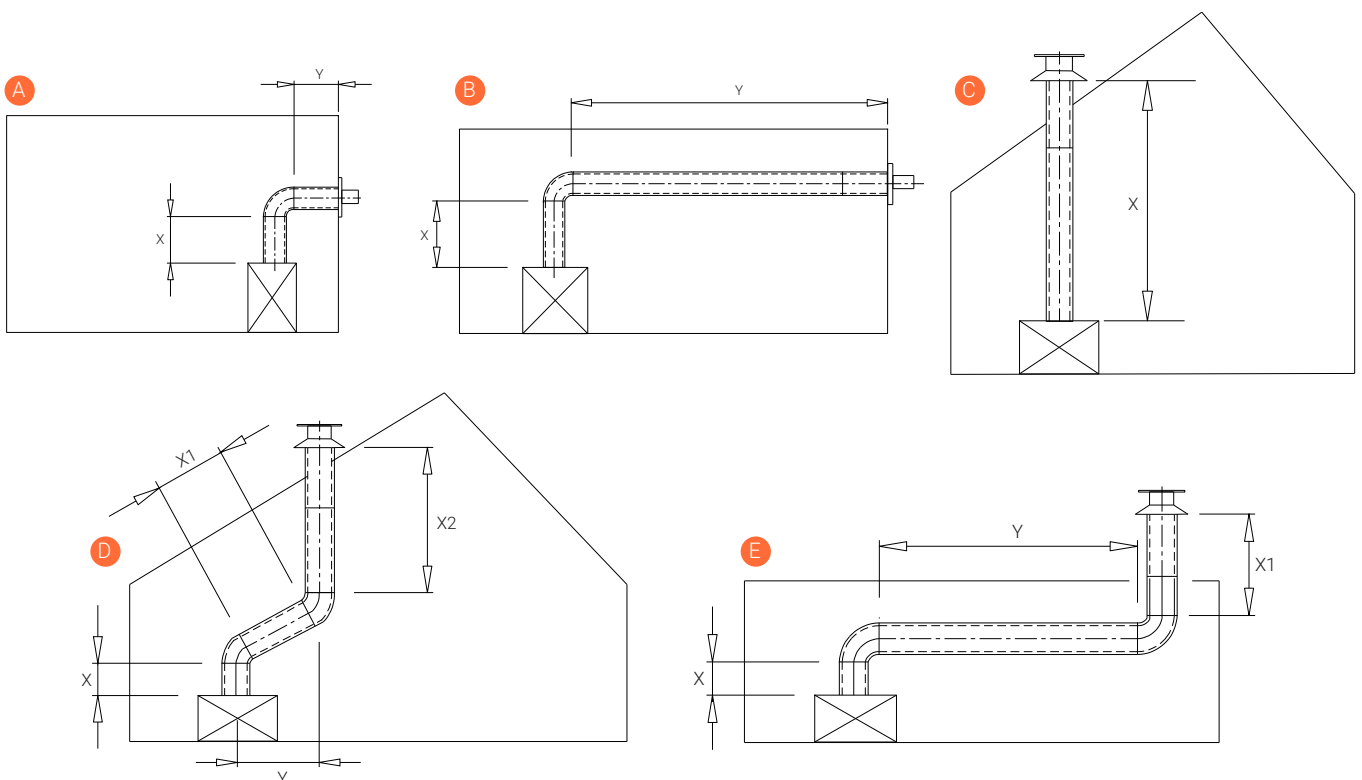

8 CONCENTRIC FLUE SYSTEM

The concentric flue system is composed of an inner flue and an outer flue. These flues have been set up concentrically so the combustion gases will be discharged via the internal flue while the fresh combustion air is supplied via the gap between the inner and outer flues.

8.1 Components of the concentric flue system

Different connections are possible using the concentric flue system. These are:

Through the roof face and through the exterior wall

The pathway used for this system can be laid in different ways, but there are a few important conditions:

- The total allowed vertical flue length must not exceed 12 metres (the sum of the flue length and calculation lengths for the bends). See *Chapter 7 Concentric pathways*.
- 90° bends have a 2-metre horizontal calculation length.
- 45° bends have a 1-metre horizontal calculation length.
- The outlet can be installed at any point on the roof face or exterior wall (supply and discharge in an identical pressure area), but must meet applicable regulations.
- Flue pathways must not be insulated.

NOTE

- Ensure the restrictor is mounted in the correct manner, as indicated in these instructions.
- The correct restrictor will provide the appliance with the most optimal efficiency, flame image and combustion.
- Mounting an incorrectly placed restrictor may cause malfunction of the appliance.

8.2 Construction of concentric flue system

Indirect wall connection

- The outlet may also be installed in an upwards exhaust in the wall, taking any hindrance to the surrounding area into consideration, in accordance with local standards and regulations.

NOTE

Ensure wind pressure on the outlet is not excessive, such as in locations with a balcony, flat roof, corners and very narrow alleys, etc., as this can negatively affect the performance of the appliance.

- Make a recess in the façade of around 155mm or 205mm when using respectively Ø100-150 and Ø130-200 flues (keep an extra space of 50mm in a refractory façade around the outer tube) and fit the façade pass-through with the wall plate on the inside of the wall. The wall plate of the exterior façade pass-through must be sealed sufficiently against the wall on the outside to avoid moisture and/or flue gas leaks leaking into the living space. We recommend our clearance box use as a direct façade pass-through through a refractory façade.

- The flue should be encased if necessary. Even if the flue is to be installed along non-refractory materials, sufficient fire-resistant measures must be taken.
- Determine the position of the appliance and outlet and begin construction of the flue with the connection on the appliance, paying attention to the direction of installation and connecting the elements by means of clamp strips.
- An adjustable pipe can be used between the bends or when connecting to the appliance. If necessary, use wall brackets to support the flue.

Mounting using the roof pass-through option

- The flue outlet can be located at any random place on the roof face (supply and exhaust in identical pressure areas) and must meet the applicable rules and regulations.
- A roofing sheet for a flat roof or a roofing sheet lead for sloping tiled roofs can be used for a watertight duct. Use various bends for the slope, if required. The recess in the roof decking should be 50mm larger all around to ensure sufficient fire resistance.
- One needs to take into account the regulation regarding fire resistance between rooms. (For this, see the applicable local standards and regulations.) A casing of fireproof material (for example, 12mm Promatect fire-resistant plate) should be applied up to 25mm from the outer flue.
- Determine the position of the appliance and the outlet and begin the construction of the flue with the connection on the appliance (always 1 metre vertical first) pay attention to the direction of installation. The inner flue must be installed for draining purposes. Connect the elements using the clamping straps. Ensure all connections are gastight.
- An adjustable pipe can be used between the bends or when making the connection to the appliance and/or the roof pass-through. Use 2 wall brackets to support the flue on each floor.

8.3 Installation instructions regarding existing flues

APPENDIX 2

Instructions

The flue gas exhaust system falls within category: C91 and must be built in accordance with national rules and regulations and the instructions of the manufacturer, as specified in the documentation and installation instructions. This means, among other things, that the chimney pass-through must not be smaller than 150mm round/square, but no larger than 200mm, and not ventilated by grilles, etc. In the case of larger chimney pass-throughs, a flexible hose of around 150 mm may possibly be used in combination with a flexible hose of around 100mm, as described below. For other situations, consult your supplier.

8.4 Parts

Check all parts for damage before commencing the installation. For the conversion of a brick flue to concentric flue, connected to CC flue system, you need the components described in [APPENDIX 2](#).

NOTE

The renovation/sanitation set consists of parts:

- ③ Interior mounting plate
- ④ Sliding element
- ⑦ Chimney mounting plate

8.5 Installation

- Guide the flexible hose ⑤ through the existing flue ⑥.
- Attach the slider ④ to the bottom of the flexible hose and secure this in place using two Parker screws.
- Keep the bottom of the slider at the same height as the bottom of the flue or ceiling.
- Shorten the flexible hose to approximately 100mm above the chimney coping.
- Attach the mounting plate to the flexible hose on the roof ⑦, clamp it with a hose bracket. Stainless steel Ø90 to 165, secure the whole with Parker screws.
- Attach the mounting plate to the chimney coping watertight on the roof ⑦ using silicone sealant and stainless steel screws.
- Install the roof pass-through ⑨ and secure it in place using the supplied clamping strip ⑧.
- The slider ④ will protrude approximately 100mm underneath the flue or ceiling after installation.
- Attach the inner mounting plate ③ gastight against the bottom of the structural flue or against the bottom of the concrete floor using silicone sealant and screws.
- Position the appliance in accordance with the instructions of the appliance manufacturer
- Install a minimum of 1 metre of concentric flue type THC CC ①.
- Extend the concentric flue using sections up to a minimum of 100mm in the structural duct. Finally, turn the clamping strip by hand in the mounting plate inside ③.

9 PASS-THROUGH POSITIONS AND FUNCTION CORRECTLY

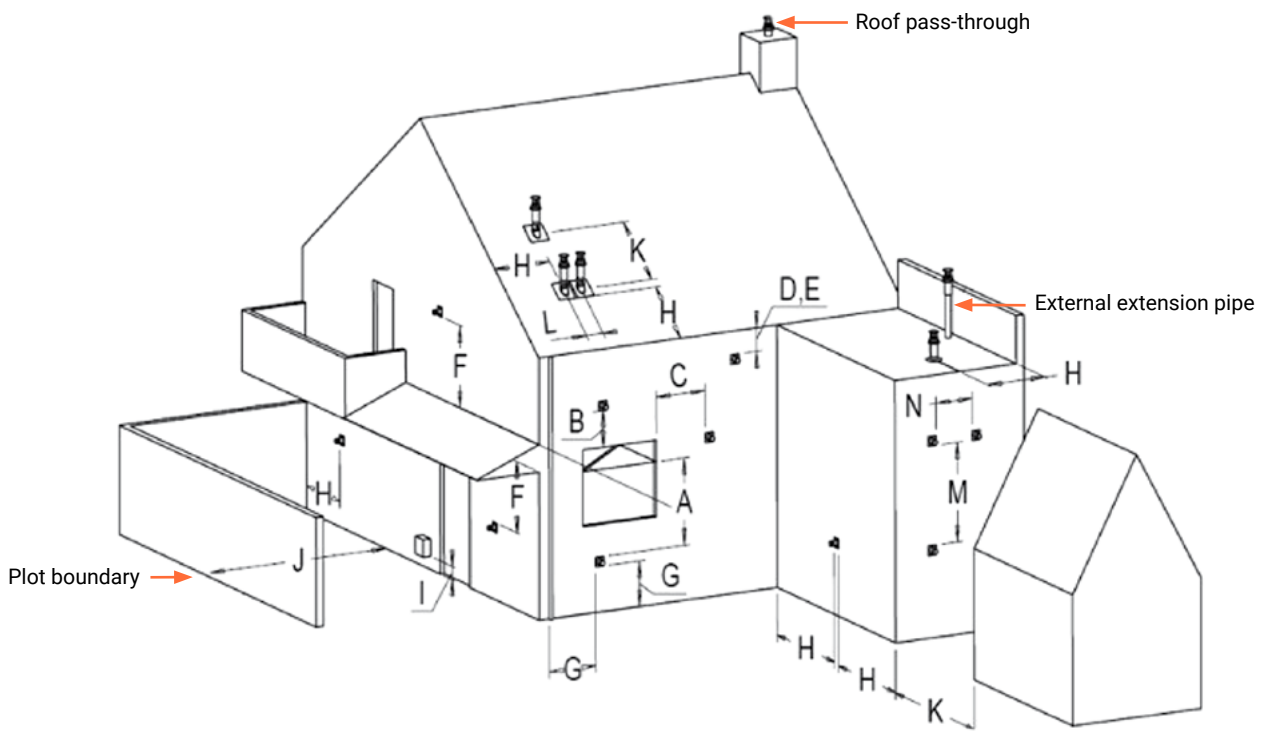

| Dimensions | Outlet positions | Distance mm |
|------------|--|-------------|
| A | Distance to ventilation openings | Room* |
| B | Distance to ventilation openings | Room* |
| C | Distance to ventilation openings | Room* |
| D | Lower gutter bottom pipes or exhaust lines | 500 |
| E | Under the eaves | 500 |
| F | Under a carport, roof or balcony, inside and outside corners | 500 |
| G | From ground level and rainwater drainage pipes | 300 |
| H | Inside and outside a corner | 500 |
| I | Above an external gas pressure regulator | 1000 |
| | Side of a gas pressure regulator | 500 |
| J | Conflict distance façade outlet | Room* |
| K | Roof drain centre to centre | 1000 |
| L | From the centre of both roof drains | 450 |
| M | Two wall drains above each other | 1000 |
| N | Two wall drains next to each other | 1000 |

* In accordance with local building codes

10 CLEANING AND MAINTENANCE

- The appliance must be checked and serviced by a recognised installer at least once a year. The glass is also cleaned during this process.
 - It is advisable to clean the outside of the appliance regularly, both in and out of the heating season.
 - Do not use aggressive or corrosive cleaning agents or sharp objects.
 - The concentric flue system must be cleaned every 2 years. A check must be carried out on:
 - 1 seal of the flue and supply circuits
 - 2 seal of the upper and lower pressure release hatches of the appliance; check the gasket
 - 3 operation of the pressure release hatches; that they can open and close freely
 - 4 the operation of the gas valve and ignition of the burner
- 5 The pressure release mechanism is located at the front **2**, at the top of the combustion chamber. Proceed as follows to remove the gasket:
- push the pressure release mechanism up from the combustion chamber
 - one of the two pressure release mechanism brackets can now be folded to the side
 - the pressure release mechanism can now be tilted away from the brackets and removed with a downwards movement
 - when fitting, make sure the pressure release mechanism bracket is folded back in place
 - check the operation of the pressure release mechanism(s)

Measuring points

The appliance has 2 measuring points on the gas valve. **1**

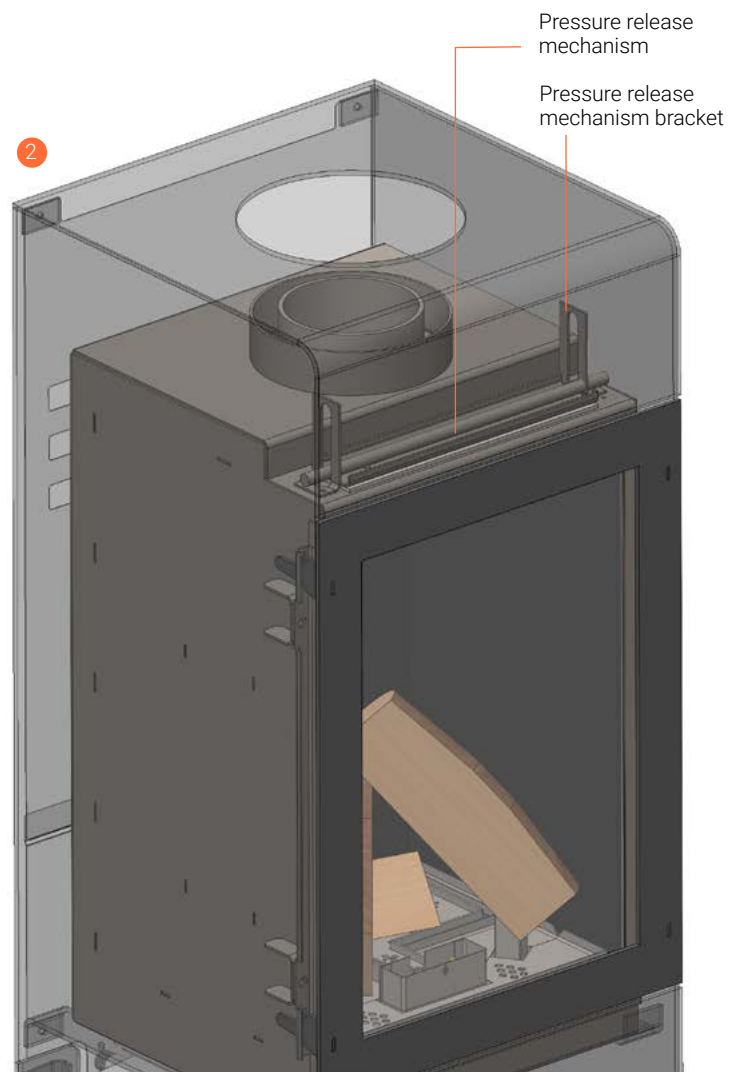
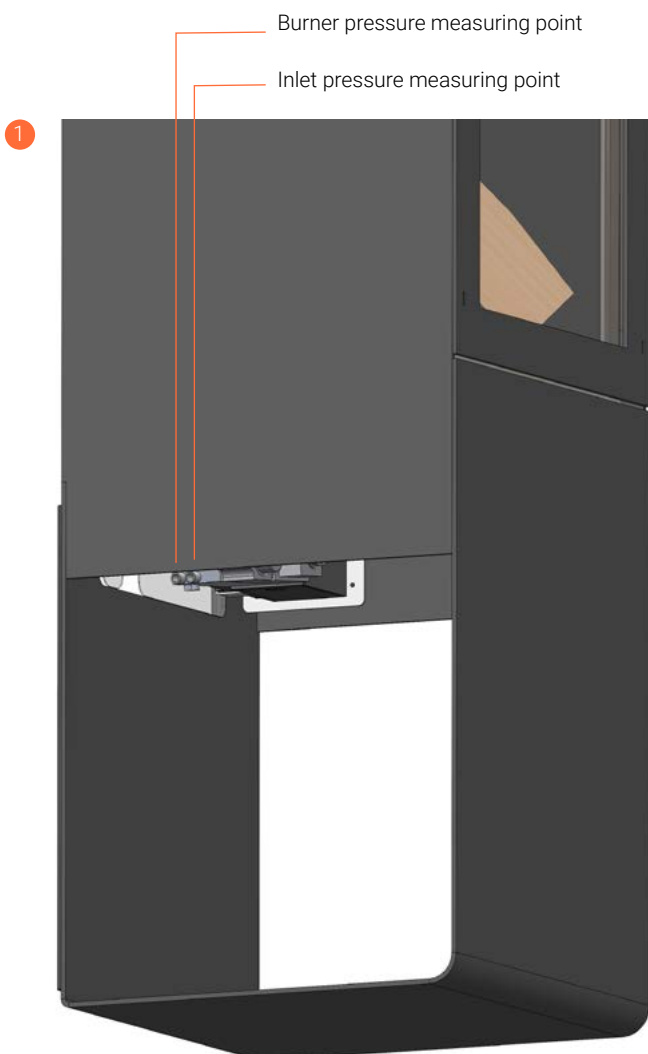

Glass cleaning instructions

Only use

Water or a suitable detergent surfactant.
We recommend our thermCet Cleaner set.

Remove the glass panel

See Paragraph *Remove frame with glass panel* on page 4.

IMPORTANT

After lighting for the first time, a haze may form on the inside of the glass panel. When the appliance has cooled down after the first use, the glass must be cleaned immediately. The glass must be cleaned again after the appliance has been in use for a month. After this, the amount of cleaning can be determined depending on the frequency of use of the appliance. Bear in mind that the glass can become dull if it is not cleaned in good time. Cleaning then becomes more difficult.

11 QUICK REFERENCE GUIDE FOR FAULTSSEARCH FOR ENCLOSED APPLIANCES USING MAXITROL GV60 GASCONTROL

| Function | Possible cause | Solution |
|--|--|--|
| 1. Acoustic signals | 1 long beep → reset switch OFF (0) | Set switch to (I) |
| | 1 long beep → connections not complete | Check connections in thermocouple circuit |
| | 1 long beep → 8-core cable defective | Check connections in connector/replace 8-core cable |
| | 1 long beep → micro switch defective | Replace gas valve |
| | 1 long beep → Sync not OK | Carry out new sync procedure for remote control/receiver |
| | 3 short beeps → mains adapter | Replace batteries or 6-VDC adapter |
| 2. No reaction remote control/receiver | Power supply problem | Check batteries/6-VDC adapter |
| | No sync remote/receiver | Carry out sync procedure |
| | Distance between remote control/receiver | Change position of receiver |
| | Defective receiver | Replace receiver |
| | Faulty remote control | Replace remote control |
| 3. No pilot flame gas | Maxitrol GV60 DC magnet appliance does not open (no clicking noise from gas valve) | <ul style="list-style-type: none"> • Check wiring and breaker on thermocouple circuit • Check/replace 8-core cable between remote control and gas valve • 1 x sparks and stop: check ground cable under torx gas valve • Replace receiver • Replace gas valve |
| 4. Poor/no spark | Spark cable loose | Check spark cable connections |
| | Short circuit between cable and metal | Check whether cable is free of metal parts |
| | Poor spark candle | Check spark candle for fractures, replace if necessary |
| | Distance of sparking candle to pilot flame head | Check distance is approximately 4mm |
| 5. Pilot light difficult to ignite | Gas supply pressure too high, nervous flame | Adjust gas supply pressure or adjust the pilot flame pressure using the gas valve |
| | Gas supply pressure too low, short flame | Adjust gas supply pressure, check gas pipes, or adjust pilot flame pressure using the gas valve |
| | Air in (pilot flame) pipe, flame on/off | Blow pipes through, make air-free |
| | Injector blocked | Clean or replace pilot flame injector |
| | Blocked/curved pilot flame pipe | Check and clean pipe |
| | Pilot light head damaged | Check and replace pilot flame |
| 6. Pilot light goes out after ignition | Small pilot flame, no flame on thermocouple tip | Check gas supply pressure, possibly too low |
| | | Check pilot flame injector and gas pipe |
| | Nervous pilot flame flame, no flame on thermocouple tip | Check gas supply pressure, too high, adjust |
| | | Adjust pilot flame pressure on gas valve |
| | Lazy pilot flame, no flame on thermocouple tip | Air in pipes, vent |
| | | Check premix opening on pilot flame, must be open |
| | Poor connections in thermocouple circuit | Check cables/breaker in thermocouple circuit |
| | | Check thermocouple connections in gas valve, do not over-tighten. |
| Measure thermocouple circuit voltage 4.5mV minimum | | |
| Bad thermocouple | Check open circuit voltage of thermocouple (18-30mV), replace if necessary | |
| Poor DC magnet appliance in Maxitrol GV60 | Replace gas valve | |

| Function | Possible cause | Solution |
|--|--|---|
| 7. Pilot light goes out when the appliance is closed | False air along pilot flame holder/gasket | Check pilot flame holder and gasket for leaks |
| | False air hatches | Check pressure hatches/gasket is completely closed |
| | Main flame causes pilot flame to go out | Check restrictor/baffle in accordance with regulations |
| 8. Pilot light/main flame off | Gas pre-pressure has dropped | Check correct dimensions of gas pipe or blockage, correct |
| | Main burner ignition, 3 beeps, low mains adapter voltage | Check batteries or 6-VDC adapter |
| | Too much/little transport in appliance/outlet | Check restrictor/baffle situation in accordance with instructions. |
| | Concentric outlet pathway incorrect | Check outlet pathway in accordance with instructions |
| | Recirculation, façade/roof mouth position incorrect | Check outlet in accordance with instructions |
| | Recirculation in closed outlet system | Check outlet connections |
| 9. Main burner does not start up | Gas control valve knob to MAN | Check gas control valve knob to ON |
| 10. Delayed ignition of main burner | Pilot light burner blocked | Check logs, pebbles, etc. are in the right position. pilot flame should be free of obstructions. |
| | Small/lazy pilot flame | Check and correct pressure and physical state of pilot flame burner |
| | Close main burner flame openings | Check and clean with a vacuum cleaner or similar device. |
| | Logs, etc. in wrong position | Check and correct, see instructions |
| 11. Low main flame | Gas supply pressure too low | Check gas supply pressure and corrections |
| | Burner pressure too low | Check burner pressure, check instructions for correct values |
| 12. No or little difference between high/low settings for main flame | Low position setting incorrect | Check and adjust low position in accordance with instructions |
| 13. DB burner does not work | Defective step valve | Check whether clicking sound is perceptible, press button on remote control several times, replace valve if necessary |
| 14. Sooty flame | Insufficient transport in appliance/closed drainage system | Check restrictor/baffle, follow instructions for correct value |
| | | Check outlet system pathway in accordance with instructions |
| | | Check outlet in accordance with regulations/instructions |
| | Excessive feed/burner pressure | Check and correct gas supply/burner pressure in accordance with instructions |
| | Blocked burner flame openings | Check and clean with a vacuum cleaner, for example |
| | Incorrect premix for main burners | Check and correct, see instructions |
| | Decorative logs, etc. in incorrect position | Check and correct, see instructions |

Appendix 1 DIMENSIONAL DRAWINGS

Trimline Zircon

Measurements in mm

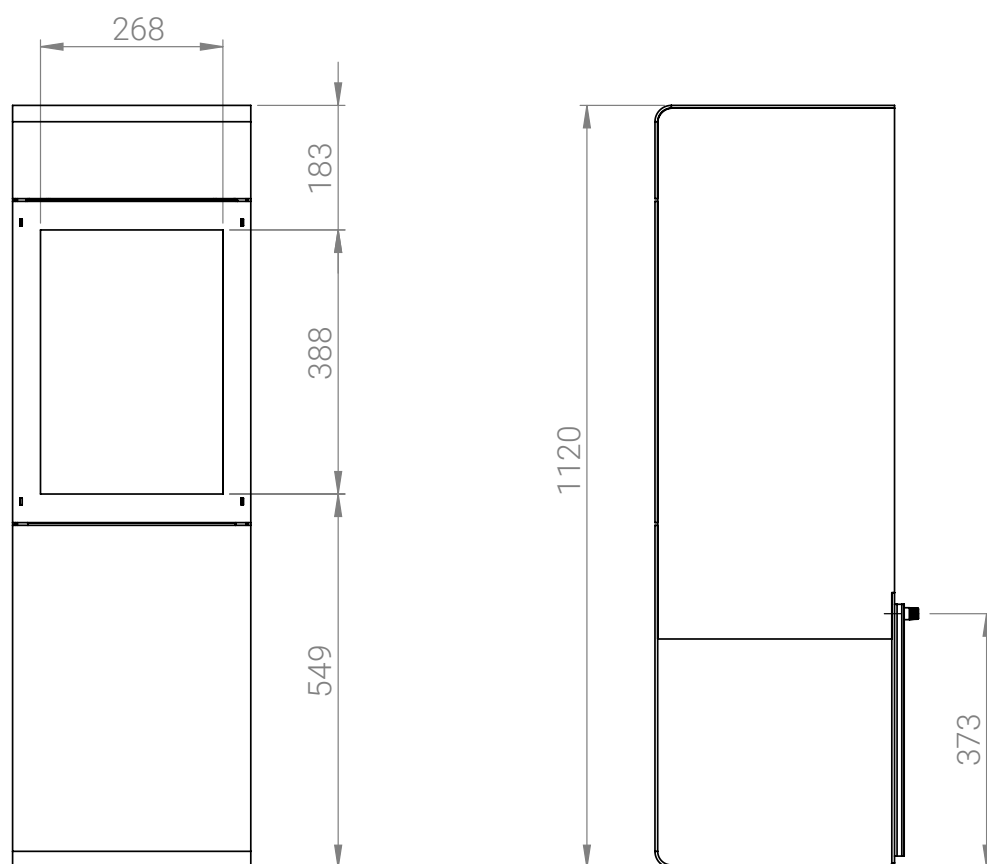
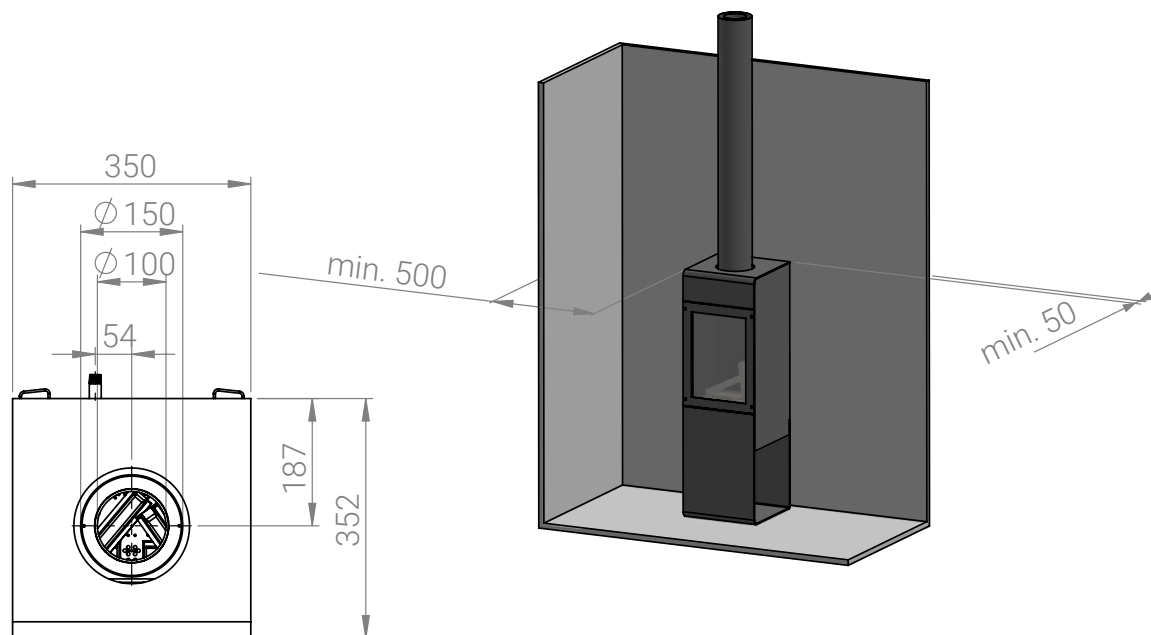

Appendix 2 CONSTRUCTION DIAGRAM DOUBLE-WALL CONCENTRIC

Material: Stainless steel AISI 316 L - Allow number 1.4404

Application: for the discharge of flue gases and the supply of combustion air from gas-fired appliances or stoves with a closed combustion system

