



# Italkero

*Wall gas stoves*

**- FORCED -**



**SR3.0 MB**

**SR5.0 MB**

**SR7.0 MB**

**SR9.0 MB**

**INSTALLATION AND  
AFTER-SALES SERVICE**

Norway  
Austria



0476  
CR0122

## COMPLIANCE

Our equipment is conforming with:

- Regulations (UE) 2016/426 (GAR)
- Electromagnetic Compatibility Directive 2014/30/UE
- low Voltage Directive 2014/35/UE
- Regulations 2015/1186 Ecolabelling
- Regulations 2015/1186 Ecodesign
- Regulations RAEE 2019/19/UE



## RANGE

<i>MODEL</i>	<i>CODE</i>
<b>3.0 aluminum</b>	SR30MB M0000
<b>5.0 aluminum</b>	SR50MB M0000
<b>7.0 aluminum</b>	SR70MB M0000
<b>9.0 aluminum</b>	SR90MB M0000
<b>3.0 white</b>	SR30MB M0300
<b>5.0 white</b>	SR50MB M0300
<b>7.0 white</b>	SR70MB M0300
<b>9.0 white</b>	SR90MB M0300

*Dear Customer*

*We inform you that this unit has a warranty specification (see specifications in the text to follow). During the first switch on, there may be vapor emissions, or bothersome odors absolutely not dangerous. In these cases, you should do operate the device at the maximum power for several hours, keeping the room well ventilated.*

*Kind Technical*

*We thank you for choosing the appliance. We can assure you its performance will be long lasting, reliable when it is installed and used properly (manufacturer's guidelines are followed).*

*Good work and thanks*

*The Manufacturer.*

---

## WARRANTY

Provided that it is fitted in accordance with the Manufacturer's instructions, this appliance benefits from the statutory warranty.

## GENERAL

General informations	pag.5
Safety rules	pag.5
Appliance description	pag.6
Identification	pag.6
Structure	pag.7
Technical data	pag.8
Accessories	pag.8
Electrical scheme	pag.9
Control panel	pag.10

## INSTALLATION

Receiving the product	pag.11
Weight and dimension	pag.13
Installation: <b>WALL FITTING</b> or <b>FLOOR STANDING</b>	
- Apparatus choice location	pag.14
- Intake & exhaust tube fumes assemblage	pag.15
-- Tube Kit Ø 32 o Ø 54 mm with unique term. (Standard)	pag.17
-- Tube Kit Ø 32 o Ø 54 mm with single term. (Speciale)	pag.18
- Appliance assemblage	pag.23
External activator connection	pag.24
KIT "FLOOR STANDING" support structure	pag.25
KIT "PROTECTION FOR WALLS MADE OF WOOD PANELS"	pag.26
Electrical collegaments	pag.27
Gas connection	pag.27

## CUSTOMER SERVICE

Preliminary operations	pag.28
First service start	pag.28
Processor control box malfunction	pag.29
Controls during the first & after starting service	pag.29
Gas transformation	pag.30
Regolation	pag.31
Ordinary maintenance	pag.32
Appliance clean out	pag.32
Components replacement	pag.33
Disassembly & reassembly of the casing	pag.37
Eventual anomalies & remedies	pag.37
Useful information	pag.39

*In same parts of the book there are used these symbols:*













**Attention:** it used to underline particular caution or actions.









**Prohibited:** it used to underline the actions that don't half to be executed.

## GENERAL INFORMATIONS

-  After removing the packaging, check the integrity of the contents. In case of discrepancies, contact the Agency that sold the appliance.
-  The appliance must be installed by an authorised company pursuant to Law. After installation, such company should issue the owner with a declaration of conformity of proper installation, according to current national regulations and any local regulations pursuant to Art. 17 of law no. 46/90 and the instructions provided by the Manufacturer in the installer's booklet that accompanies the product.
-  The APPLIANCE must be used as intended by the Manufacturer and for the purpose for which it was expressly built.  
The Manufacturer disclaims any contractual and non-contractual liability for injury to persons and animals and damage to things caused by installation, adjustment and maintenance errors or improper appliance use.
-  If the APPLIANCE is not used for a long period of time, the following operations will have to be performed:
  - position the master switch of the appliance on "OFF"
  - position the master switch of the system, if fitted, on "OFF" or disconnect the plug from the power socket.
  - close the gas tap
-  The appliance should be serviced at least once a year.
-  This booklet is an integral part of the appliance and must therefore be carefully looked after and ALWAYS accompany the APPLIANCE, including when this is sold to another user or transferred to another system.  
In case of damage or loss, ask the Area After Sales service of the Manufacturer for another copy.
-  Always make sure that curtains or other objects do not obstruct the suction filter and the room air outlet vent.
-  Only connect the appliance to properly earthed power sockets.
-  Only install the appliance in dry environments (protection IP 20)
-  The appliance must not be operated wherever there are hazardous materials, vapours or liquids.
-  Install the appliance on a flat surface to prevent any malfunction.

## SAFETY RULES

- We like to remember that, products that use combustion or electrical energy there is security rule to observe before operating.
-  Do not allow children to be near the appliance.
  -  It is prohibited to turn on an electrical device if there is a gas smell.  
In this case:
    - Open windows and door.
    - Close the gas tap.
    - Call a Technical Service Assistance.It is prohibited to touch the appliance with wet hand or other parts of your body.
  -  -Electrical Hazard: Do not touch the appliance with wet feet or other part of your body.
  -  It is prohibited to clean the appliance when it is running.
  -  It is prohibited to pull, remove and wring electric wires outside the appliance also if the electrical supply is turned off.  
It is prohibited place over the appliance, towels, tea clothes and other could be cause of inefficiency or also source of hazard.
  -  It is prohibited to leave paper, plastic, or other things of the appliance box outside within a child's reach.  
It could be potential source of hazard.

## APPLIANCE DESCRIPTION

The appliance is a gas radiator that heat up the atmosphere.

It has an intake of air that goes in the combustion chamber type C.

The appliance is made with an aluminium body that allows a high efficiency of heat; it also has a fan that allows the dispersal of air faster in the rooms.

The appliances are arranged in factory for the function at gas methane and they can be transformed to GPL(G30/G31) using the furnished nozzle kit.

Note: At request the apparatus can be furnished already arranged at GPL.

It also has an electrical device that allows you to do a series of things.

There also is a Processor Control Box (P.C.B assy) that controls all the principals' function of the apparatus.

After there is the Control Panel that has other options.

## IDENTIFICATION

The appliance is identified through:

### - Packed label:

A label that indicates the code and the combustion it uses to identifies the appliance.

### - Technical label:

The technical label reports the matrices numbers, the gas prearrangement, and technical observation.

### -Gas prearrangement label:

It reports the kind of gas the appliance has to use, and if there is a transformation from one kind of gas to another you have to change the old label.

⚠ Spare parts, or technical operation require, a precise identification of the type of model.

If there is going to be any tampering of the technical label, this will not consent the right identification of the apparatus.

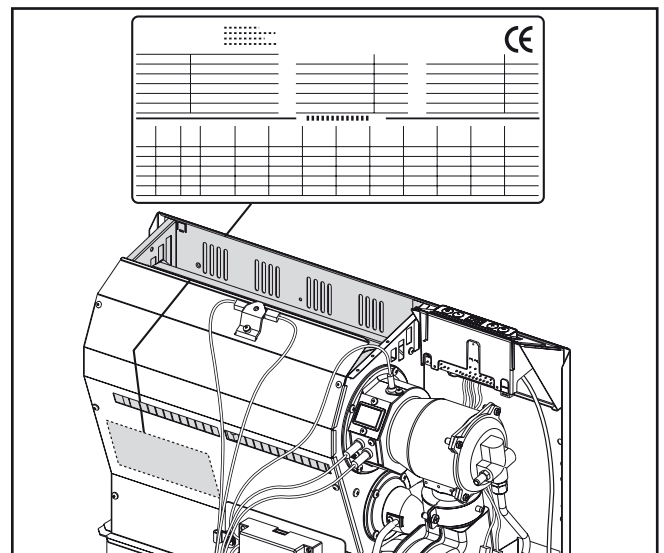
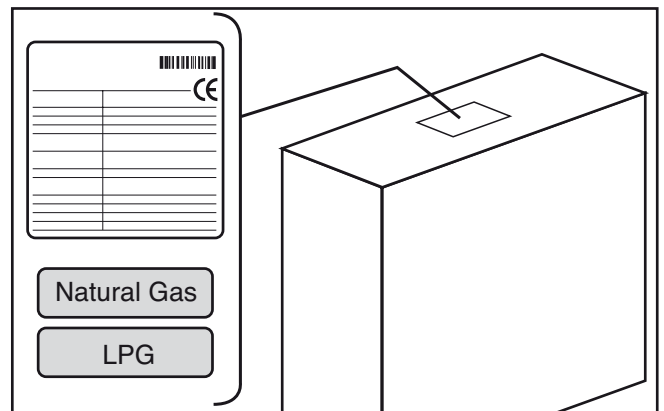

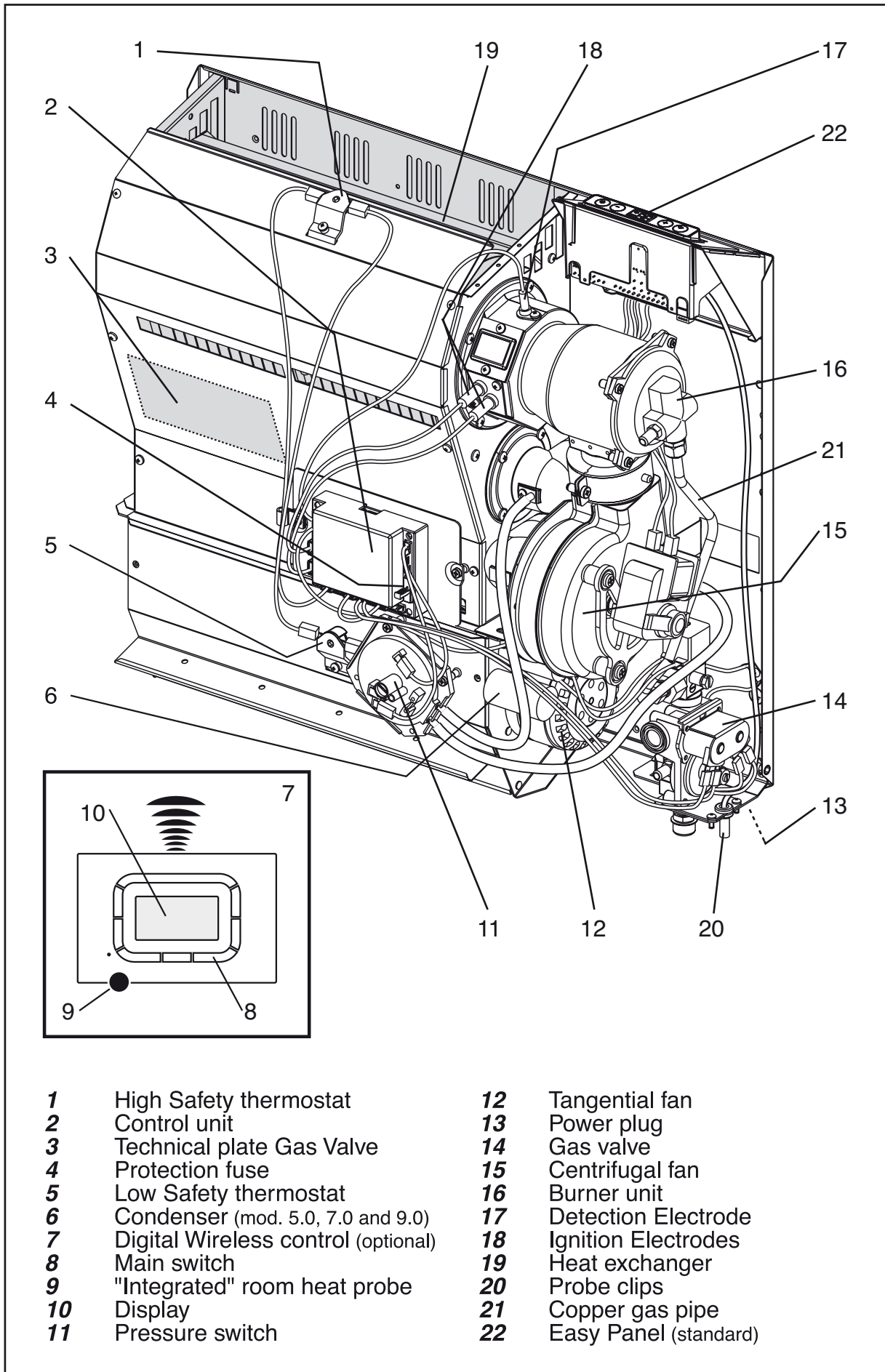

## TECHNICAL DATA

MODEL	3.0		5.0		7.0		9.0			
	G20	G30/G31	G20	G30/G31	G20	G30/G31	G20	G30/G31		
Terminal capacity nomination (qn) (Hi)	2,50		4,70		6,80		8,60	8	kW	
Terminal capacity reduction (qn) (Hi)	2,32		4,34		6,25		7,74	7,20	kW	
Terminal power convector nomination (pn) (Hi)	1,70		3,30		4,80		5,70		kW	
Terminal power convector reduction (pn) (Hi)	1,58		3,05		4,41		5,13		kW	
Right efficiency	93		92,4		91,9		90		%	
Nozzle pressure	12	28,9/28,9	12	28,8/28,8	12	28,6/28,6	11	28,4/28,4	mbar	
Reduce nozzle pressure	7	15,0/15,0	7	15,0/15,0	7	15,0/15,0	6	14,8/14,8	mbar	
Gas consumption (15°C)	G20	0,264		0,497		0,719		0,909	m³/h	
	G30/G31		0,195/0,194		0,370/0,368		0,535/0,530		0,677/0,670	kg/h
Gas consumption reduction (15°C)	G20	0,179		0,348		0,507		0,602	m³/h	
	G30/G31		0,134/0,133		0,260/0,258		0,378/0,375		0,449/0,447	kg/h
Type of apparatus	C13 - C33 - C43 - C53 - C63									
Combustion category	II <sub>2</sub> H3B/P									
Efficiency class	1									
NOx class	5									
Nozzle	3									
	0,82	0,47	1,10	0,63	1,33	0,78	1,50	0,85	n°	
Max/min value Atmospheric heated by a convector	78/46	78/46	166/78,8	166/78,8	197/115	197/115	246/143	246/143	m³	
Quantity of air heated	130		225		335		419		m³/h	
Electrical alimentation	230~50									
Power absorbed when in function	80			60						W
Protection degree	IP20									
Weight with the convector in box	23,5		30		36,5		42,5		kg	

## ACCESSORIES

DESCRIPTION	Code
Floor Standing 3.0	70001435 00
Floor Standing 5.0	70001440 00
Floor Standing 7.0	70001445 00
Floor Standing 9.0	70001450 00
WIRELESS	70000990 00
90°curves Ø 32mm pipe union	70000700 00
Extension Ø 32mm L = 500mm	70000720 00
Extension Ø 32mm L = 1000mm	70000710 00
135°curves Ø 32mm	70000705 00
Outer protection grille "GP" for separate end piece Ø 32mm	70000350 00
Griglia prot. esterna "GPu" per Term. Unico Ø 32mm	70000600 00
Recessed screen "SDP" for separate end piece Ø 32mm	70000365 00
Stack for pipe Ø 32mm	70000730 00
90°curve Ø 54mm pipe union	70000370 00
Extension Ø 54mm L = 500mm	70000390 00
Extension Ø 54mm L = 1000mm	70000380 00
90°curve Ø 54mm cast	70000755 00
135°curves Ø 54mm	70000375 00
Outer protection grille "GP" for separate end piece Ø 54mm	70000350 00
Outer protection grille "GPu" for combined end piece Ø 54mm	70000610 00
Recessed screen "SDP" for separate end piece Ø 54mm	70000365 00
Stack for pipe Ø 54mm	70000740 00
INSULATION for pipe Ø 32mm L = 1000mm (pack of 5 pcs.)	70000840
INSULATION for pipe Ø 54mm L = 1000mm (pack of 4 pcs.)	70000850 00
Inlet/Outlet end piece Ø 32mm L = 5 cm	70000466
Inlet/Outlet end piece Ø 54mm L = 6 cm	70000465 00
SPECIAL OUTLETS KIT (pipes from inside the room) Ø 32mm	TP3206A5 00
SPECIAL OUTLETS KIT (pipes from inside the room) Ø 54mm	TP5410A5 00
CHIMNEY Weathering, INCLINED ROOF Ø 54mm	70000725
CHIMNEY Weathering, FLAT ROOF Ø 90mm	70000726 00
COAXIAL END SECTION KIT Ø 110 mm (ROOF installation) Ø 54mm	70000445 00
Special Pipes Kit Ø 32 mm (2 single term.)	TP32SP 00000
Special Pipes Kit Ø 54 mm (2 single term.)	TP54SP 00000

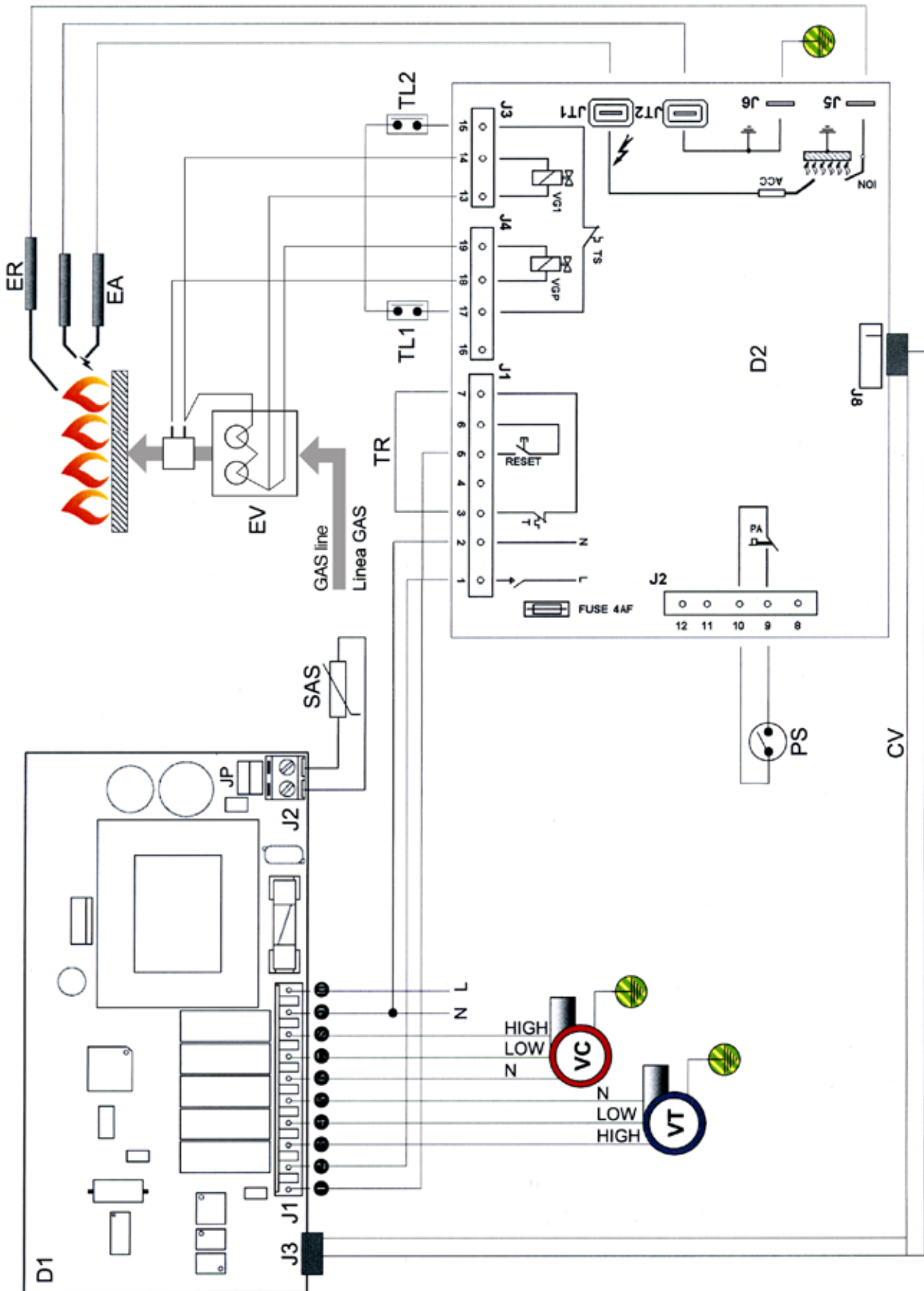

## CONTROL PANEL

- 1 - On/Off key and device RESET
- 2 - Reduce temperature key (MIN 5°C)
- 3 - Light display
- 4 - Increase temperature key (MAX 35°C)
- 5 - Enable/disable Wireless command key

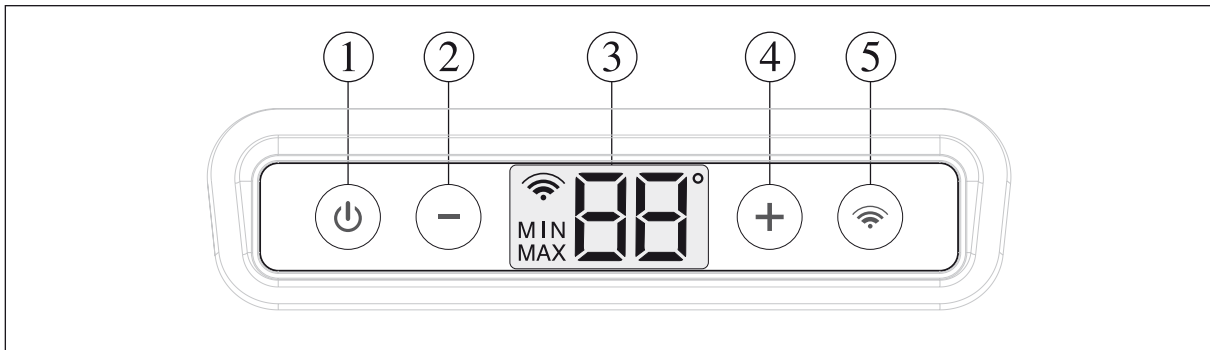

### DESCRIPTION OF DISPLAY

This type of screen simultaneously provides an entire series of information:

- MIN operating power.
- MAX operating power.
- Wire command enabling.
- ambient temperature.
- desired ambient temperature.
- degrees centigrade unit scale.
- data transmission

### DESCRIPTION OF ICONS

- 1 - operation at MAX power.
- 2 - operation at MIN power.
- 3 - data transmission between the device and the Wireless command (intermittent icon).
- 3b - Wireless command enabled (fixed on icon).
- 4 - Detected ambient temperature.
- 4b - Desired ambient temperature.

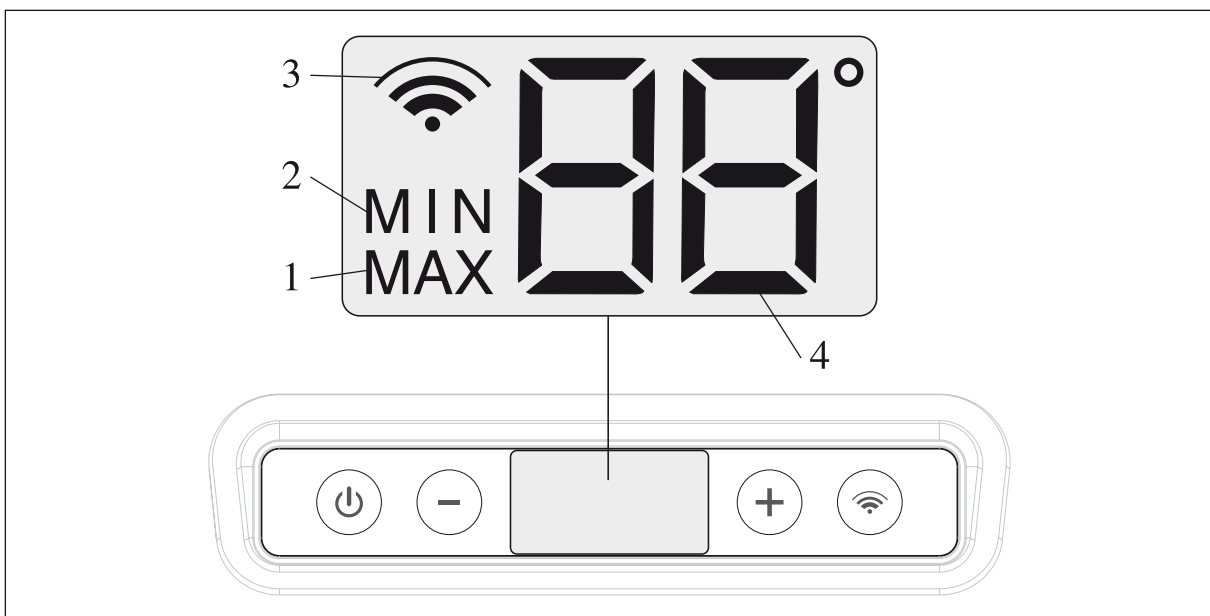

The appliance is supplied in one cardboard package:

Contents of appliance package:

- 1 Appliance
- 1 Manual control
- 1 Metal template
- 1 Pipe KIT:
  - 1 Adapter union
  - 1 Suction pipe (L = 500mm)  
(Ø 32mm Mod. 3.0 - 5.0)  
(Ø 54mm Mod. 7.0 - 9.0)
  - 1 exhaust pipe (L = 500mm)  
(Ø 32mm Mod. 3.0 - 5.0)  
(Ø 54mm Mod. 7.0 - 9.0)
  - 1 Single outer end piece + anchors  
(Ø 32mm Mod. 3.0 - 5.0)  
(Ø 54mm Mod. 7.0 - 9.0)
- 1 Document envelope:
  - 1 instruction booklet
  - 1 Gas transformation kit
  - 1 Spare parts catalogue
  - 1 Warranty certificate
  - 1 Warranty labels
  - 1 Power socket
  - 1 Paper template

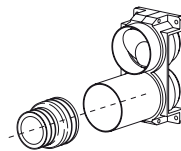
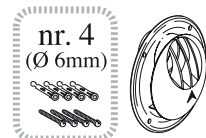
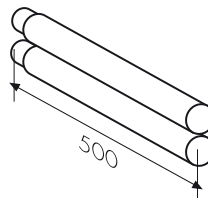
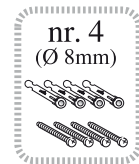
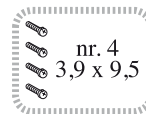
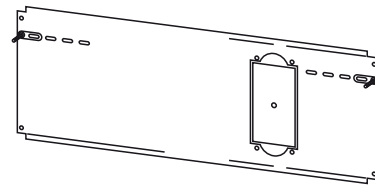
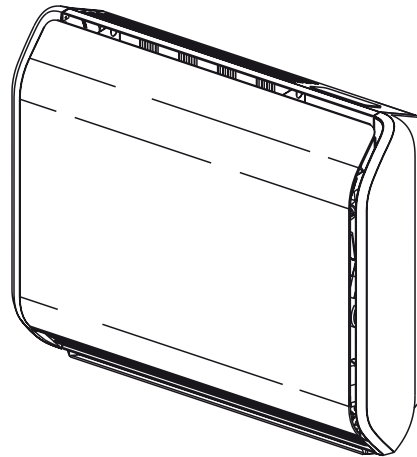

### SPLIT PIPE KIT WITH SINGLE PIPE END PIECE (SPECIAL)

- Ø 32 pipe kit with single pipe end piece (TP32SP 00000)

Contents of kit package:

Qty	Description
1	Paper template for appliance positioning
4	Anchors Ø 8 mm (for fastening the template on the wall)
1	Adapter connection for Ø 32 mm pipes and fastening screws
3	curves Ø 32 mm
3	Pipes Ø 32 mm L=500 mm
2	Pipes Ø 32 mm L=1000 mm
2	Pipe end pieces Ø 32 mm
2	Stainless steel flanges
8	Anchors Ø 6 mm
8	Self-threading screws for fastening the pipes Ø 3.9 mm
4	Self-threading screws Ø 4.2 mm
1	antivibration reducing socket

For installation details, see INSTALLER Section.

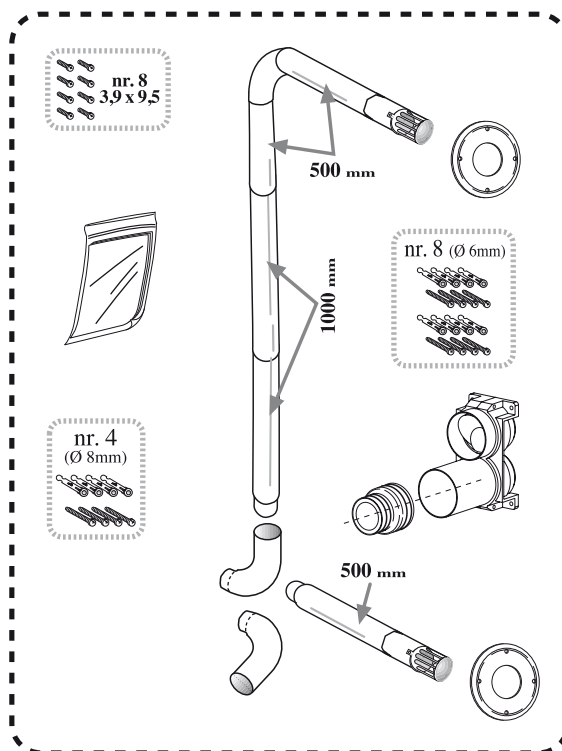

### SPLIT PIPE KIT WITH SINGLE PIPE END PIECES (SPECIAL):

- Ø 54 pipe kit with single pipe end pieces (TP54SP 00000)

Contents of kit package:

Qty	Description
1	Paper template for appliance positioning
4	Anchors Ø 8 mm (for fastening the template on the wall)
1	Adapter connection for Ø 54 mm pipes and fastening screws
2	Cast angle curves Ø 54 mm
3	Pipes Ø 54 mm L=500 mm + o-ring
2	Pipes Ø 54 mm L=1000 mm + o-ring
2	Pipe end pieces Ø 54 mm + o-ring
2	plastic rings
2	diaphragms (only for Mod. 3.0 - 5.0)
1	M/F curve + o-ring
8	Self-threading screws for fastening the pipes Ø 3.9 mm
4	Self-threading screws Ø 4.2 mm
1	antivibration reducing socket

For installation details, see INSTALLER Section.

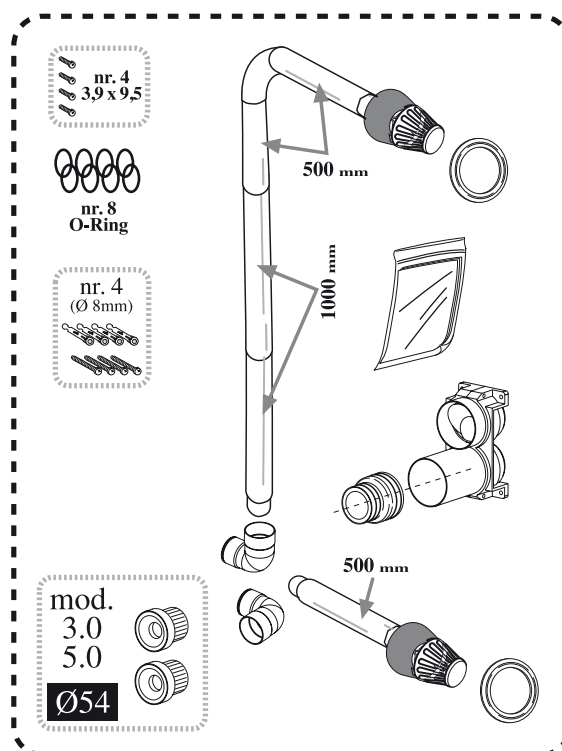

### Verify Tube kit

When the Appliance is being installed be sure that all the tubes are adjusted for the installation you want done. The tube kits available are:

<i>MODEL</i>	<i>Description</i>	<i>CODE</i>
<b>30-50</b>	KIT special EXHAUST & INTAKE Ø 32mm (2 SINGLES)	TP32SP 00000
<b>30-50-70-90</b>	KIT special EXHAUST & INTAKE Ø 54mm (2 SINGLES)	TP54SP 00000
<b>30-50</b>	KIT special EXHAUST & INTAKE Ø 32mm (1 INDIVIDUAL) <b>INTERNAL Installation</b>	TP3206A5 00
<b>30-50-70-90</b>	KIT special EXHAUST & INTAKE Ø 54mm (1 INDIVIDUAL) <b>INTERNAL Installation</b>	TP5410A5 00

## WEIGHT & DIMENSION

DESCRIPTION	<b>3.0</b>	<b>5.0</b>	<b>7.0</b>	<b>9.0</b>	
Width ( C )	535	685	835	985	mm
Depth ( B )	225	225	225	225	mm
Height ( A )	585	585	585	585	mm
Weight	20,7	27	33	38,7	kg

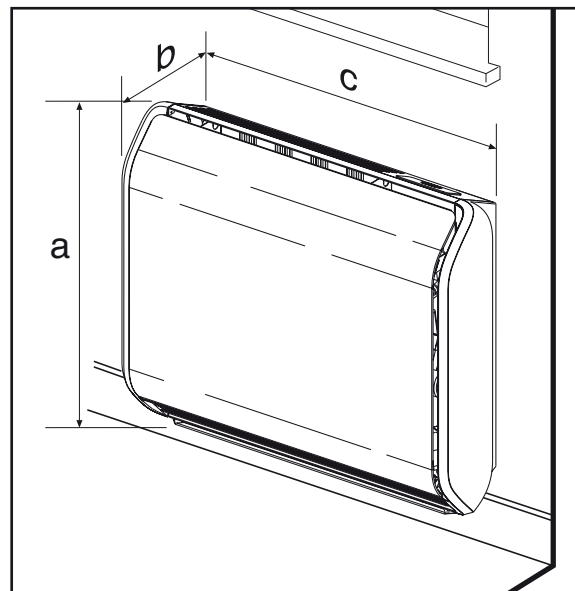

## INSTALLATION: WALL FITTING or FLOOR STANDING

### GENERAL INFORMATIONS

This apparatus is tin respect to the environment; the air is intake from the outside.

-When the appliance is being installed do not use other pieces that are not give from the manufacturer.

-Don't let the electrical cable touch heated parts, like the grill or the intake & exhaust tubes.

Is the installation duty to tell the owner the behaviour to keep during the apparatus function.

-Don't block with cloths or rug the apparatus intake & exhaust tubes.

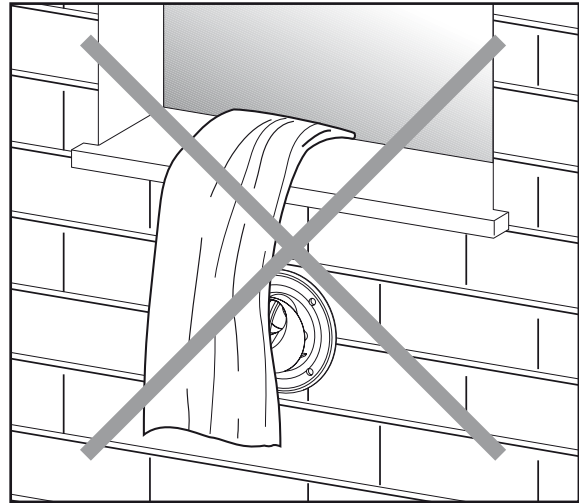

### APPARATUS CHOICE LOCATION

Before you're going to install the appliance, check if there is enough space for the correct function of the appliance.

Check if around the appliance tubes there are materials that can support the heath, second check if the wall is made of the right material and can support the appliance weight.

Verified if around the exhaust fumes tubes, there is no wood or plastic but there is the right material that can support the heath.

The material where the appliance it going to be placed has to resist the exhaust tube heath (about 180°C).

 In case of low resistant wall material it's possible to realize a cavity around the exhaust fume tube, and insulate with strong material for the present temperature, otherwise execute a hole with a larger diameter at least 4 cm respect to the exhaust fume tube.

 Its prohibited settles the appliance in rooms like bath, or showers. For this installation you need to realize special protections that make the apparatus consistent to the Electrical security rules.

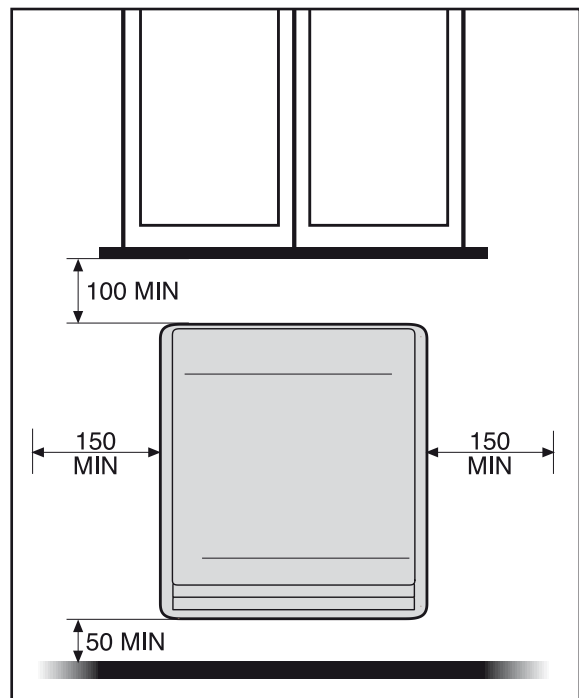

## Installation stage

The appliance installations stages are:

- Apparatus choice location
- Tube installation
- Parallel tube kit  $\varnothing$  32 mm or  $\varnothing$  54 mm with unique terminal (standard)
- Separated pip kit  $\varnothing$  32 mm or  $\varnothing$  54 mm with single terminal (special)
- Appliance installation
- Electrical collegaments
- Gas connection

## TYPE OF INSTALLATION SECOND UNI CIG 7129

As we go on we are going to show you the types of installation second by the Uni Cig 7129 rule.



**C63: free installation UNI CIG 7129 with approved flue.**

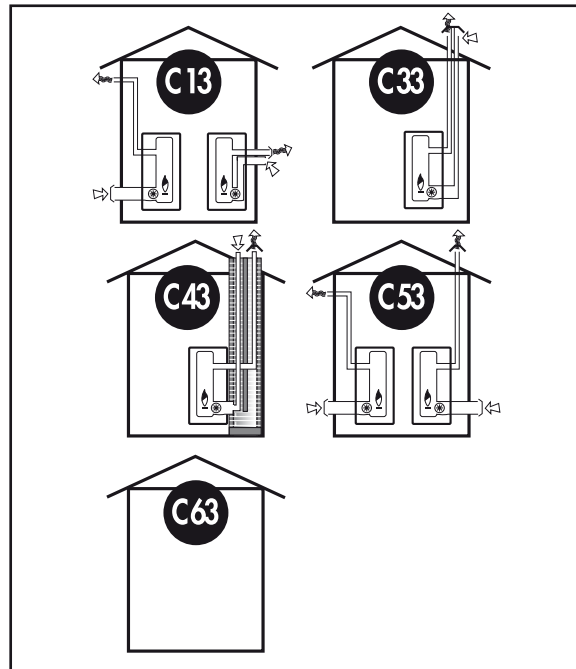

## INTAKE AND EXHAUST TUBE FUMES ASSEMBLAGE

The intake & exhaust tubes can be **embedded** inside the wall, or in **sight**, they have to be protected to avoid, risk condition. To have the apparatus in sight it exist a spacing bar so that you can see the tubes, **we recommend that the exhaust tubes have to have a good insulation using materials that have also a resistant of more 200° C°** (ex. HT-/Armaflex) of temperature. Realize the holes for fastening the tubes, after establish the hangers' length; insert it in the right position.

**Before assembling the tubes kit verifying that the Max tube length has been respected, even the Max loaded loss provided** (See table).

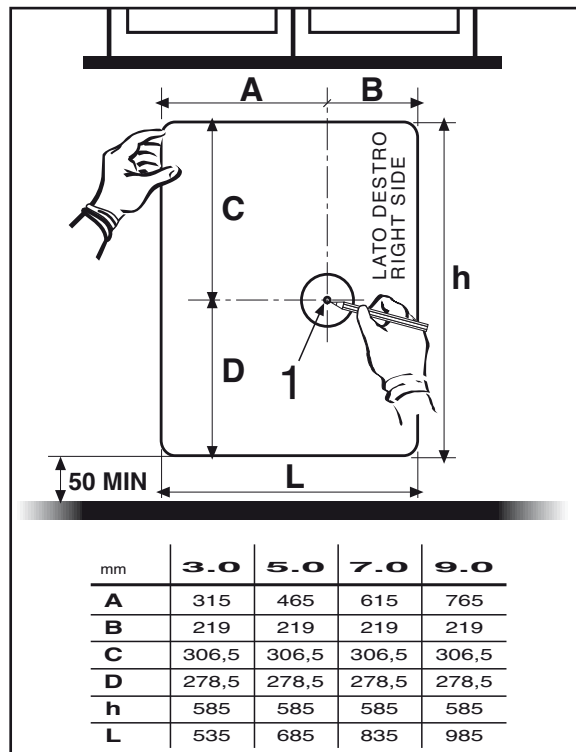

	3.0		5.0		7.0	9.0	
$\varnothing$ unloaded intake tubes	32	54	32	54	54	54	mm
$\varnothing$ Wall hole common terminal tubes	65	110	65	110	110	110	mm
Max separate terminal tube length	10	15	3	15	15	10	m
Max common terminal tube length	5	15	1	15	15	10	m
Min comprehensive tube length	80		80		80	80	mm

	3.0		5.0		7.0	9.0	
Loaded loss tube l= 500 mm	3	0,5	6	0,6	0,8	1,2	Pa
Loaded loss tube l =1000 mm	5	0,7	11	1	1,6	2,25	Pa
Loaded loss tube curve 90°	5,8	0,7	12,2	1,5	0,05	0,7	Pa
Loaded loss tube curve 90°diecast	-	4,4	-	9	0,3	4,3	Pa
Loaded loss single terminal	5	2	9	4	4	6	Pa
Loaded max loss permissible (*)	50	20	50	20	30	25	Pa

(\*) - Sum of the pressure leak both air suction and gas exhaust pipes.

## FITTING THE TEMPLATE, UNION AND PIPES

To determine the position of the APPLIANCE and of the support template (3), use the paper template (4) provided:

- level and mark the holes (1, 2), then remove the paper template from the wall;
- make the holes (2) for fastening the template to the wall;
- make the centring hole (1), through the entire wall thickness;
- make the hole for the suction and discharge pipes using the centring hole (1);  
**Ø 65 mm hole for Ø 32 mm pipes or Ø 110 mm hole for Ø 54 mm pipes.**

⚠ So as not to damage the outer part of the wall to be drilled, we suggest making the hole in two stages: starting from the inside (A) and ending on the outer side (B).

- remove the plate (5);
- fit the adapter union unit (6) on the template, using the screws provided;
- cut the pipes to the thickness of the wall adding 25 mm, then eliminate the excess parts.

⚠ **The cut must be perpendicular to the pipe axis, being very careful not to deform these. After cutting, carefully remove any burrs.**

To make it easier to fit pipes with O-rings, use silicone grease or a soapy solution and make sure the O-rings do not exit from their seats.

In the event of the spacer support being used, the template + unit + pipes must be fastened directly on the support and the pipes must be fitted in the slots provided on the support.

- fit and fasten the pipes (7) on the unit (6);
- level the template + unit + pipes;
- insulate the exhaust pipe (8) and fit the pipes in the hole in the wall;

⚠ **Before fastening the pipes, only for lengths greater than 50cm, insulate the fume exhaust using material resistant to temperatures above 200 °C (e.g. HT-/Armaflex).**

- fasten the template + unit + pipes on the wall using the screw anchors provided (2);

⚠ **Use the screw anchors most suitable for sustaining the weight and suitable for the material of which the wall is made and to which it is being fastened.**

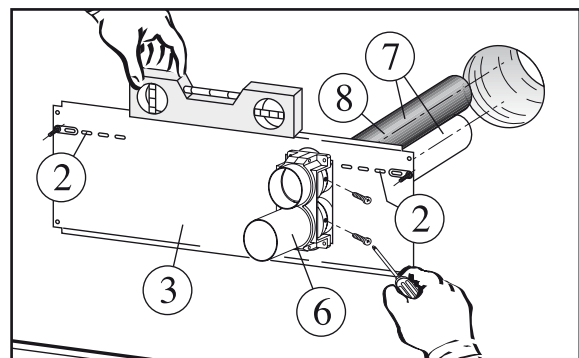
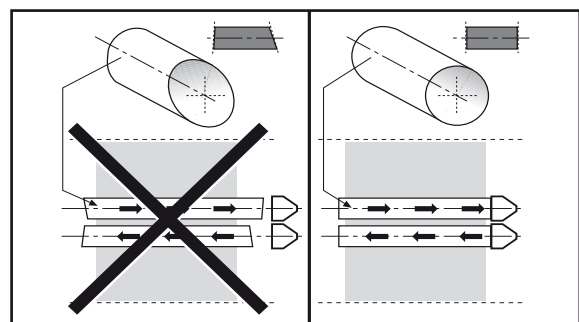
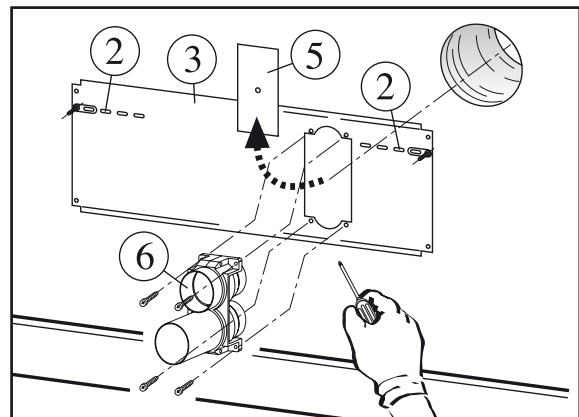
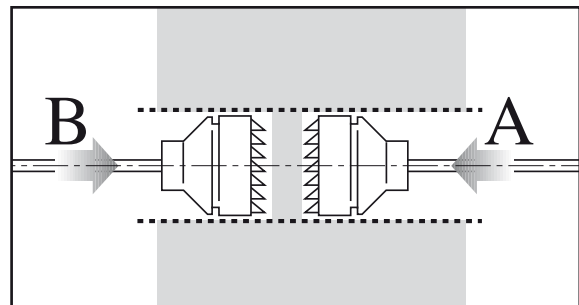
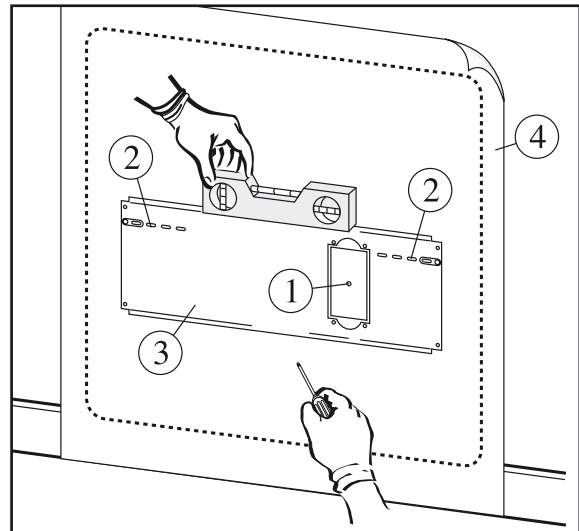

### Outside grill assemblage GP and GPu

To assemble the grill you only need the inserts, and the steelness steel flange.

### Assemblage SDP protection

The assembling is execute in the following way:  
 -After you have drilled on the outside wall put the protection (1) with mortar  
 -Assemblage the terminal tube with the equipment screws  
 -Adapt the terminal to the tube length and grill (2) protection between the walls.  
 The tube cuts have to be perpendicular being real careful do not deform.

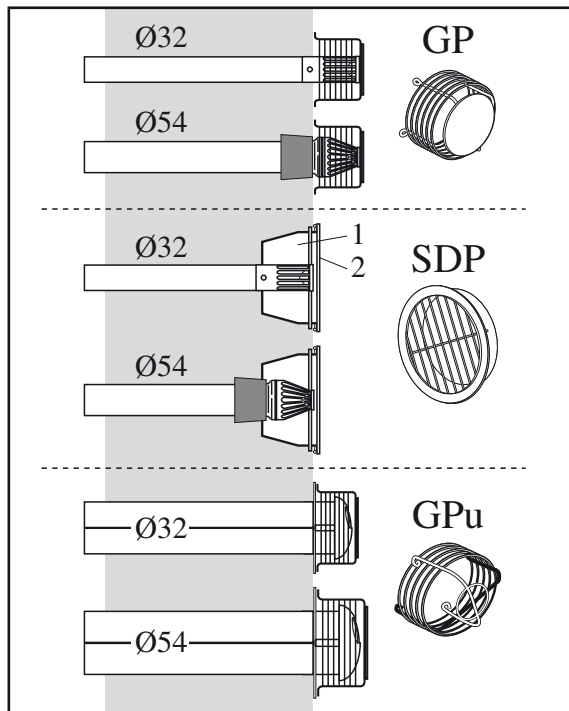

### Kit parallel tube Ø 32/54 mm with unique terminal (standard)

This kind of system is used when the exhaust fume and the intake of air are next to the apparatus.

### Assemblage the adapter tubes connection unique terminal, from the out side.

- Insert in the wall the assembled group adapter connection, angles, and curves.
- Position the exhaust/intake tubes at thread outside wall, being real careful that the short tube is always up (exhaust tube)
- Fasten the group adapter connection to the template with the screw set.
- Insert the unique terminal until the plastic ring touches the wall.
- Mark with a punch the holes for the fastening
- Cut the terminal then make the hole for the inserts Ø 6 mm
- Fasten the unique terminal to the wall using the inserts Ø 6mm seeing that the exhaust tube is toward up.

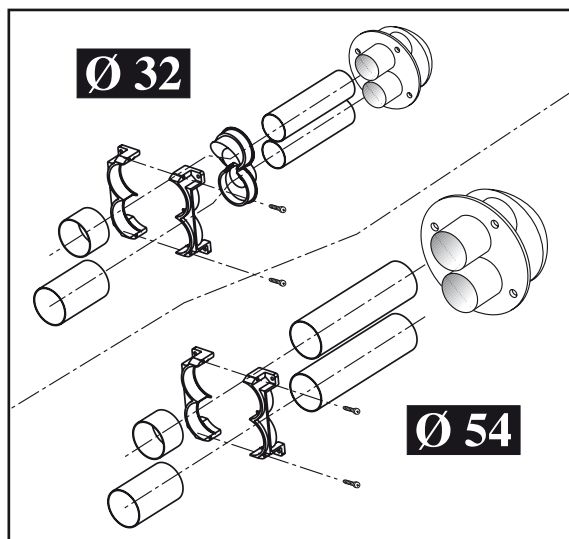

**!** Ascertain that the adapter tubes connections are correctly inserted. To fasten the tubes assemblage, use silicone grease and verified that the O-ring don't come out from there seating.

**!** Before you wall up the tubes, only for lengths greater than 50cm, provide to insulate the exhaust fume tube with material resistant to the 200° C° (ex. HT/-Armaflex).

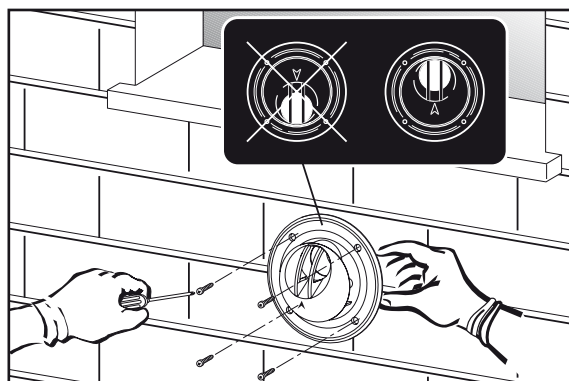
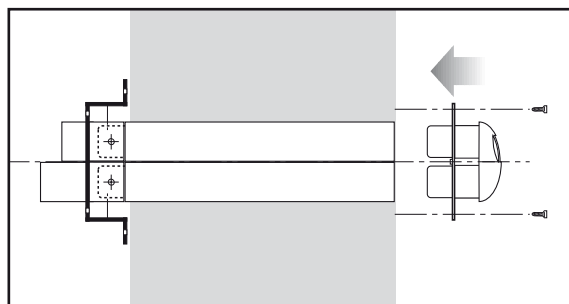

**How to mount special pipes kit from inside the room to be warmed.**

Drill the hole on the wall. Shorten the special pipes in order to match the real thickness of the wall (see picture).

**IMPORTANT:** Cutting must be perpendicular to the pipe axis, please handle with care in order not to deform the pipes.

Before you insert the pipes through the hole you must fix the SPECIAL KIT to the fitting connector by screws on issue.

Insert the whole assembling (Special kit + fitting connector) through the hole on the wall.

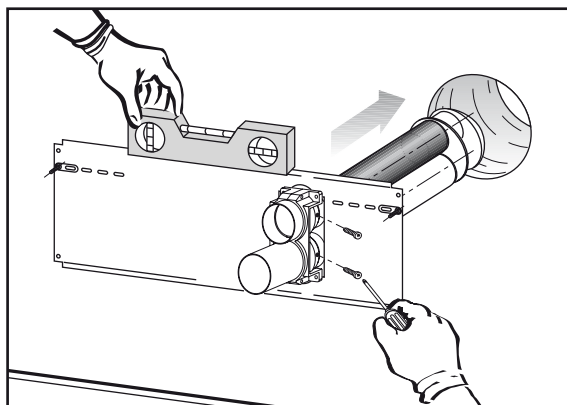

**Tube kit Ø 32 mm o Ø 54 mm with unique terminal (SPECIAL).**

This kit, uses separate tubes and are indicated when the exhaust fumes and intake are fore way the apparatus.

The type of installation are more than one kind, but they can be lead to the 3 example described in this chapter.

**!** Before pipes kit assemblage, verifying **maximum pipes length be respected, considering the maximum pressure leak consented (see below chart).**

	<b>3.0</b>		<b>5.0</b>		<b>7.0</b>	<b>9.0</b>	
Ø unloaded intake tubes	32	54	32	54	54	54	mm
Ø Wall hole common terminal tubes	65	110	65	110	110	110	mm
Max separate terminal tube length	10	15	3	15	15	10	m
Max common terminal tube length	5	15	1	15	15	10	m
Min comprehensive tube length	80		80		80	80	mm

	<b>3.0</b>		<b>5.0</b>		<b>7.0</b>	<b>9.0</b>	
Loaded loss tube l= 500 mm	3	0,5	6	0,6	0,8	1,2	Pa
Loaded loss tube l =1000 mm	5	0,7	11	1	1,6	2,25	Pa
Loaded loss tube curve 90°	5,8	0,7	12,2	1,5	0,05	0,7	Pa
Loaded loss tube curve 90°diecast	-	4,4	-	9	0,3	4,3	Pa
Loaded loss single terminal	5	2	9	4	4	6	Pa
Loaded max loss permissible (*)	50	20	50	20	30	25	Pa

(\*) - Sum of the pressure leak both air suction and gas exhaust pipes.

## Chances A1/A2 tube assemblage in wall.

This solution can be adapted when the wall thickness consent to execute the trace for the connection tubes, and can be realize in two ways:

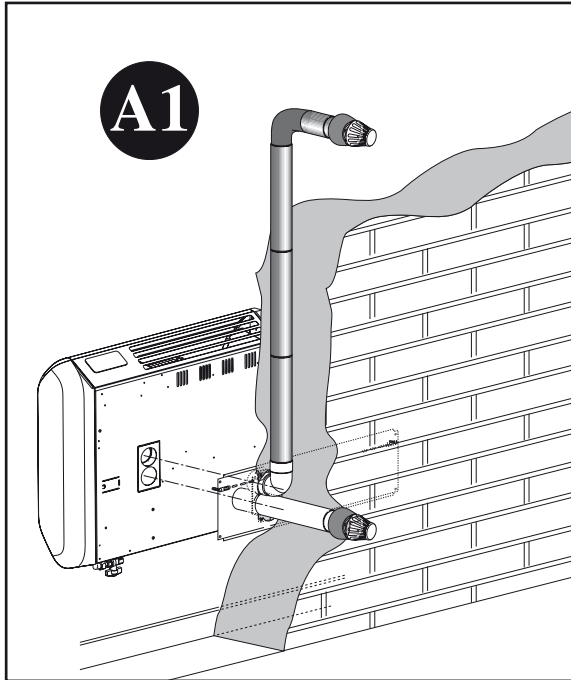

⚠ Before you wall up the tubes, only for lengths greater than 50cm, provide to insulate the exhaust fume tubes, with strong materials resistant at a greater temperature of 200 °C (ex. HT-Armaflex).

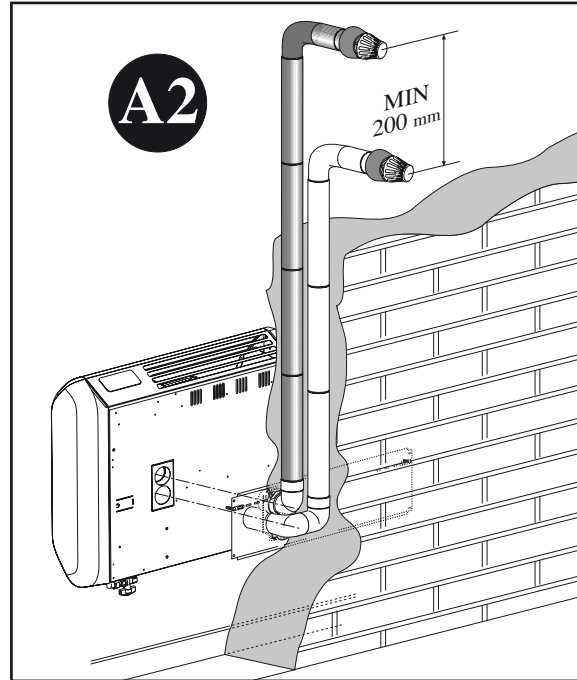

### -Chance A1 (with tube Ø 32 & 54 mm)

To install the fume exhaust and air suction pipes:

- level, mark and make the hole for the pipes (1) and the holes (2) for fastening the template (3).
- remove the plate (5) and fit the unit (6) on the template;
- mark the wall for housing the bend and remaining pipes.

⚠ Before fitting the pipe kit make sure both **the MAX length of the pipes and the MAX acceptable load loss have been respected** (see Table).

- fit and fasten the pipes on the unit;
- fasten the template + unit + pipes on the wall using the screw anchors provided;

⚠ Use the screw anchors most suitable for sustaining the weight and suitable for the material of which the wall is made and to which it is being fastened.

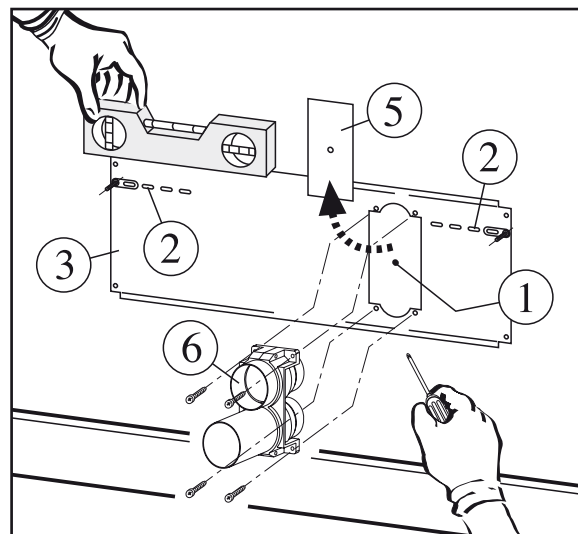

## Group adapter connection tube

The group adapter preparation is effected by two kinds of tubes  $\varnothing$  32/54 mm

### -- With $\varnothing$ 32 mm tubes.

- Adapt the length tube; to the wall space so it increases 25 mm, then cut it.

- Assemble the tube (1) cut at right measure, and the curve (2) for the adapter connection (3) then fasten with the furnished screws.

The exhaust tube has to be toward up and in correspondence to the shortest outside tube of the adapter connection.

- Assemble the single terminal (4) on the tube (1) fastening with the furnished screws in the way that extremity tube appears at line of the terminal but-hole.

- Fasten the adapter union to the template.

### -- With $\varnothing$ 54 mm tubes

- Adapting the length tube; to the wall space so it increases 25 mm, then cut it.

- Open the group adapter connections disassemble the two flanges (1) unscrew the screws (2) take off the reductions (3 only for the 0 32mm tubes) then assemble the group.

- Assemble the single terminal (4) to tube (5).

 The cut has to be perpendicular to the axe tubes, being real careful don't deform. At the cut, take away real carefully the featheredge, after make the fastening holes.

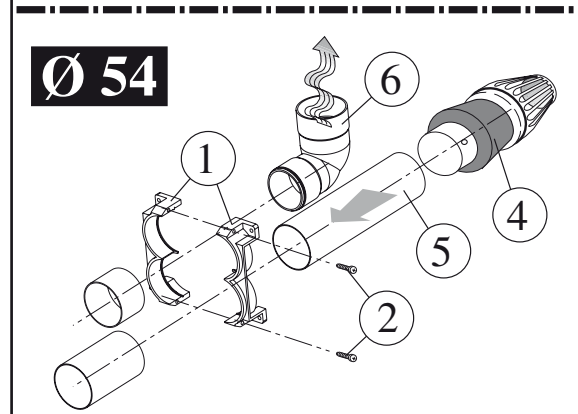
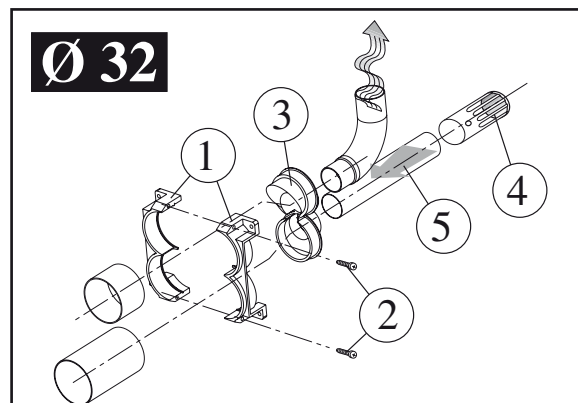
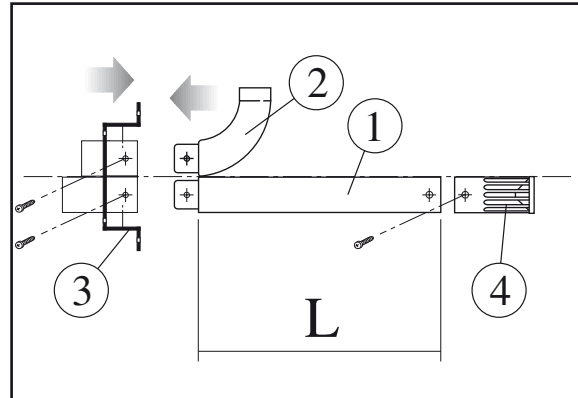
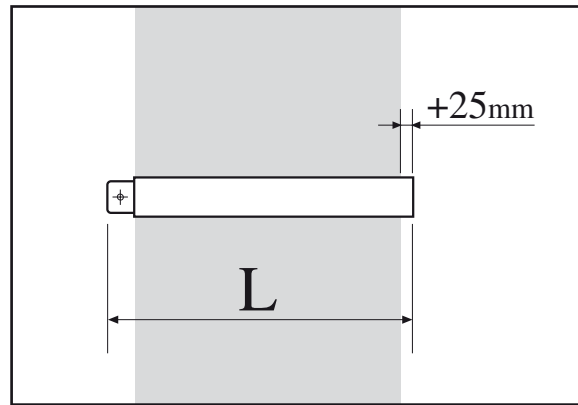

## Chance A2 with Ø 32/ 54 mm tubes

To install the fume exhaust and air suction pipes:

- level, mark and make the hole for the pipes (1) and the holes (2) for fastening the template (3).
- remove the plate (5) and fit the unit (6) on the template;
- mark the wall for housing the bend and remaining pipes.

**!** Before fitting the pipe kit make sure **both the MAX length of the pipes and the MAX acceptable load loss have been respected** (see Table).

- fit and fasten the pipes on the unit;
- fasten the template + unit + pipes on the wall using the screw anchors provided;

**!** Use the screw anchors most suitable for sustaining the weight and suitable for the material of which the wall is made and to which it is being fastened.

### Group adapter connection tube

The group adapter preparation is effected by two kinds of tubes 0 32/54mm.

#### -- With Ø 32 mm tubes

- Assemblage the group adapter connection curves, and fastens in position with the furnished screws. Knowing the single terminal tubes directions.

- Fasten the adapter union to the template.

- Complete the installation with the tubes, cut the tubes at measure (5) adapting at the actual increased wall space of 25 mm, eliminating the excess wall, making that the tube will be at thread with the terminal hole (4).

#### -- With Ø 54 mm tubes

- Assemble the die-cast angle curves (6 - only for 0 54mm tubes), on the adapter connection then fasten in position with the furnished screws.

- Rotate the curves (6) to the point that you can close the flange (1) with the screws (2). Assemble the template to the wall, and the assemble group.

- Complete the installation with the tubes, cut the tubes at measure (5) adapting to the actual increased wall space of 25mm, eliminating the part in excess, making that the tube will be at thread with the terminal hole (4).

Ascertain that the adapter tubes connection is correctly inserted. To fasten the tubes assemblage, use silicone grease and verify that the O ring don't come out from its seating.

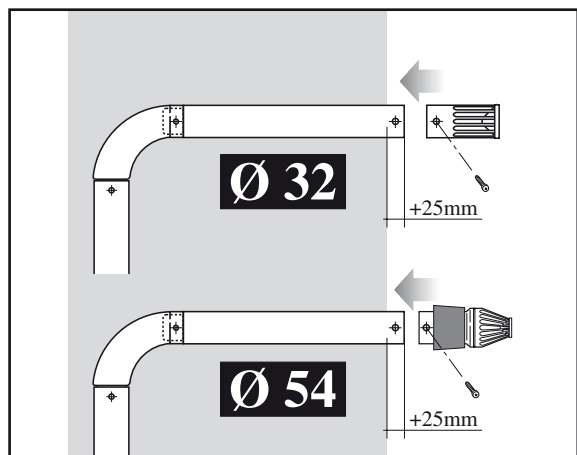
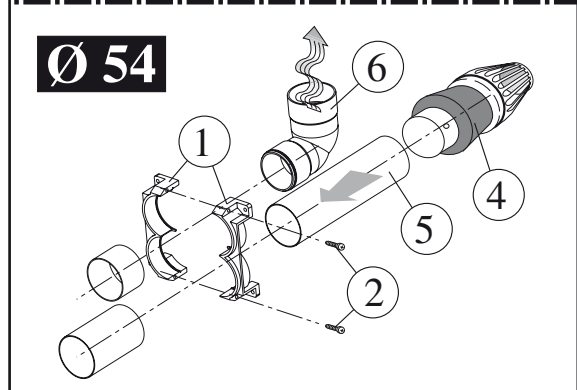
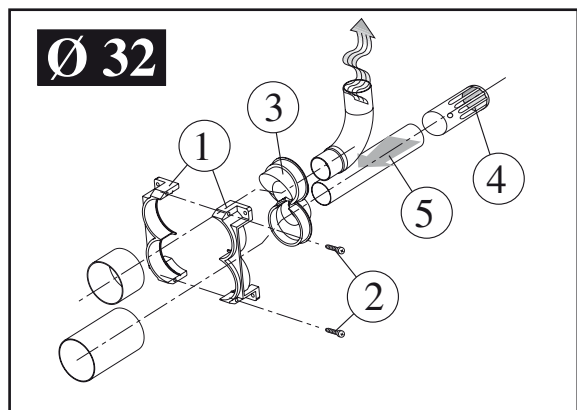
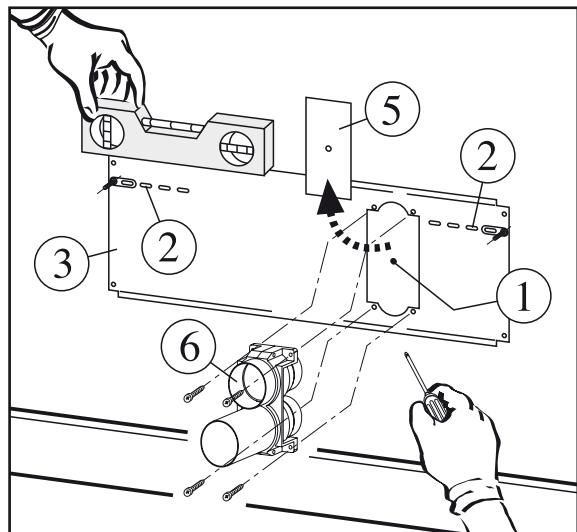

### Chance B – inside tube assemblage

This system is used when the wall does not permit to realize the proper work to install the tubes. To install the tubes you need the spacing bar (1).

Before you start the work check that there is enough space that permits the appliance to do the right function.

- Mark, execute space bar holes.

- **Prepare the group adapter connection (as chance A2)**

-- **With Ø 32 mm tubes**

- Assembles the group adapter connection curves, and fastens in position with the furnished screws.

- Fasten the adapter union to the template.

-- **With Ø 54 mm tubes**

- Disassemble the flange, exchange the stub pipes with the curves, for the comburent air tube, and the exhaust fume tube, fasten all assembling the flange.

- Fasten the adapter union to the template.

- Fasten to the wall the spacing bar support with the furnished inserts.

- Complete the installation assembling it with the rest of the tubes, fastening them to the wall with commercial clamps.

**⚠ Before you wall up the tubes, only for lengths greater than 50cm, provide to insulate the exhaust fume tubes, with strong materials resistant at a greater temperature of 200 °C (ex.HT-/Armaflex).**

### Chance C – outside tube assemblage

This solution can be adapted when the exhaust fume tubes and the comburent air intake tubes are to the outside.

**⚠ Before you wall up the tubes, only for lengths greater than 50cm, provide to the insulate the exhaust fume tubes, with strong materials resistant at a 200°C temperature (ex. HT-/Armaflex).**

- **Group adapter connection tubes**

- Fasten the group, **adapter connection** to the template with the furnished screws.

Complete the installation, assembling it with the rest of the tubes, fastening them to the wall with commercial clamps.

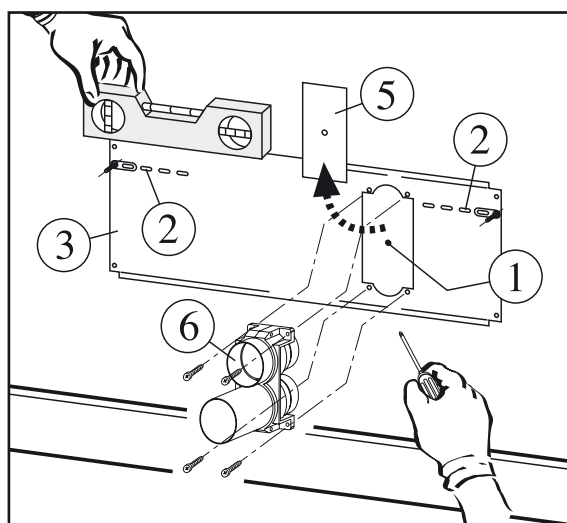
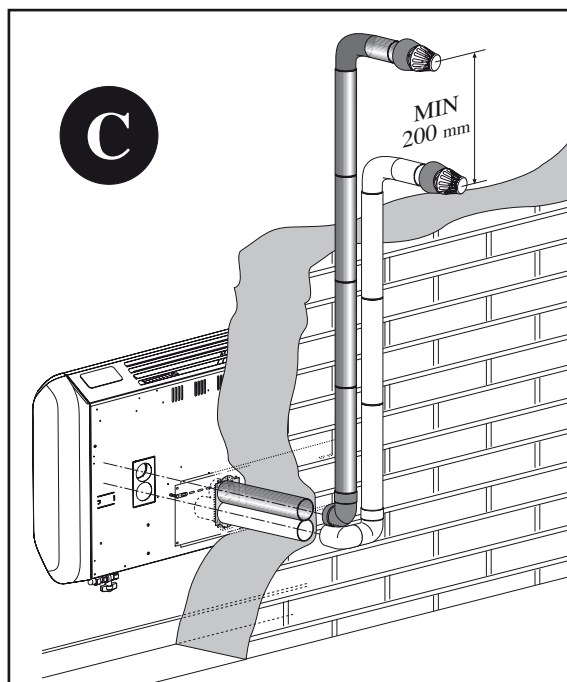
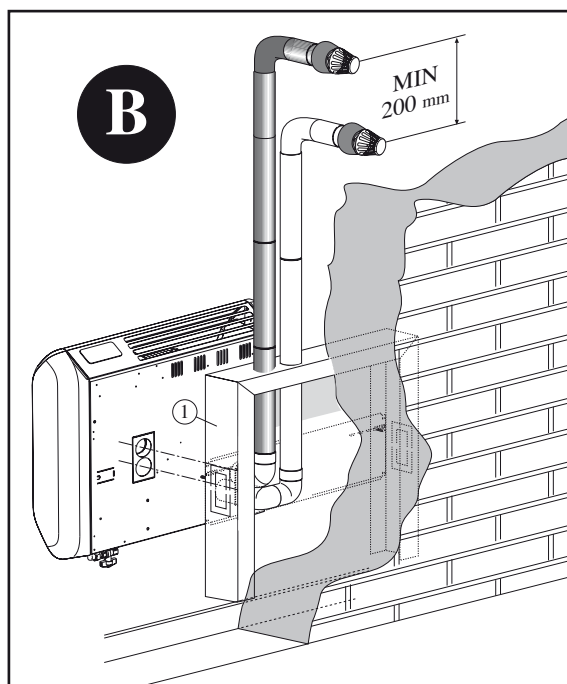

## Chimneypot assemblage

To assemble the chimneypot on the exhaust intake tubes use the clamp (1) and the (2) safety screw.

The chimneypot application has to satisfy the following requirement.

- The top of the exhaust fume tube has to be out of the ebb zone, to avoid the eventual pressures that will prevent the free exhaust product of the combustion in the atmosphere.
- The chimneypot has to be placed right on top of the tube in the proper way, if it's not placed in the proper way, the fumes will get inside the tubes, and if this happen it will cause problems to the appliance.

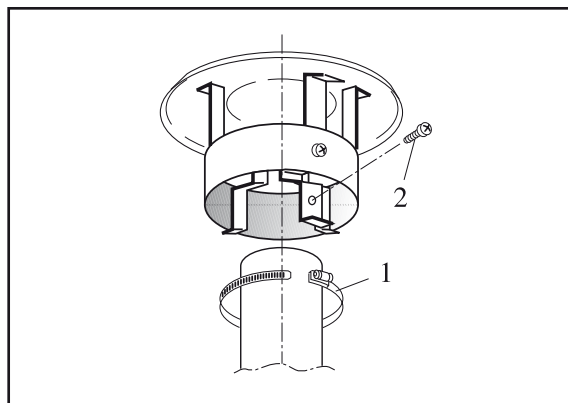

## APPLIANCE ASSEMBLAGE

The proper function of the Appliance has to be couple to the tube Ø 54 mm it foresees the application of the diaphragm (1) supplied with the apparatus equipment.

**⚠ Fitting the diaphragms (Ø 54 mm pipes only) is required and recommended only for models 3.0 and 5.0. Diaphragm fitting is NOT required for model 7.0 and 9.0.**

The diaphragm has to be inserted inside the air intake (2) and exhaust fumes (3) before assembling the terminal.

Rest the inferior part of the appliance at the inferior template adages; fasten to the wall or on the spacing bar.

- fit the antivibration reducing socket (5)

Approach the apparatus, inserting the exhaust / intake fumes curves in the right adapter connection tubes.

**⚠** To fasten the tubes use grease and be sure that the O Rings are in their seating.

Lift the apparatus, place it next to the hanger, and then fasten with stud bolt (5 MA) (4).

**⚠** Do not lift the appliance holding it from the fan, trying emitting damage.

Check the work done.

Reassemble the cover and the humidifier after the electrical and gas connection.

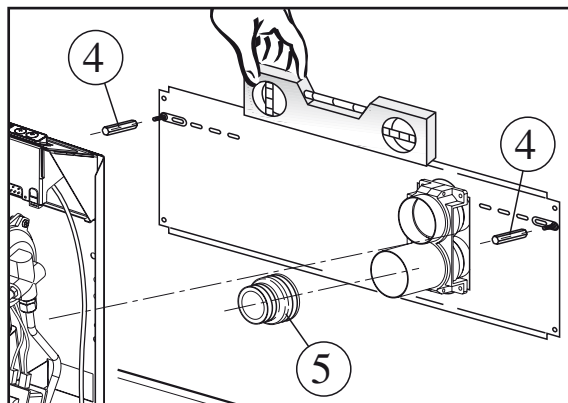
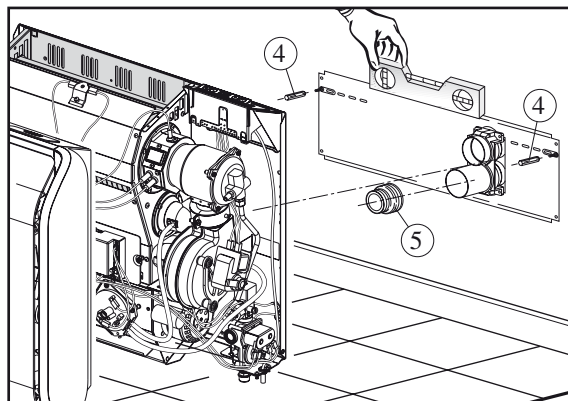
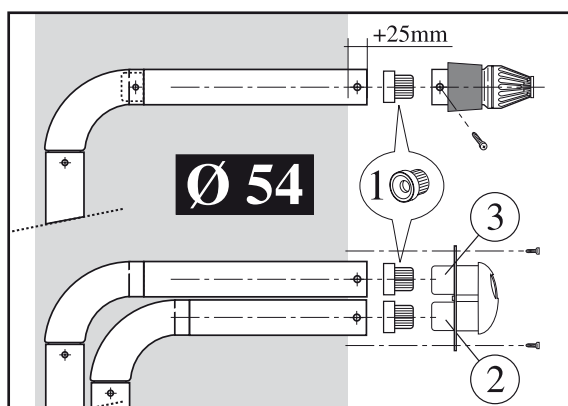

## FITTING THE REMOTE DIGITAL CONTROL

For correct installation of the remote control in the required position, follow these instructions:

- Choose the position of the remote control:
  - away from the appliance;
- Install the remote control.

**!** To ensure correct operation, install the remote control at a MAX distance of 6 metres.

- Remote control away from the appliance

This solution makes it possible to read the perfect room temperature for comfort. In fact in this position, the remote control “feels” the temperature at human height.

**!** To ensure correct operation, install the remote control at a height off the floor between MIN 1m and MAX 1.5m.

Installation:

- choose the position;
- open the remote control, fit the batteries and check:
  - Display unit operation
  - range of action (see User Sect.)

Check the range of action:

- If the LED flashes 4 times a second, reception is correct.
- If the LED flashes slowly, you are at the limit of the range of action.
- If the LED does not flash, you are outside the range of action.

- mark the position of the fastening holes on the wall and drill;
- fit the screw anchors and screws most suitable for the chosen wall;
- fasten the rear part of the remote unit to the wall;
- assemble the front part with Display unit.

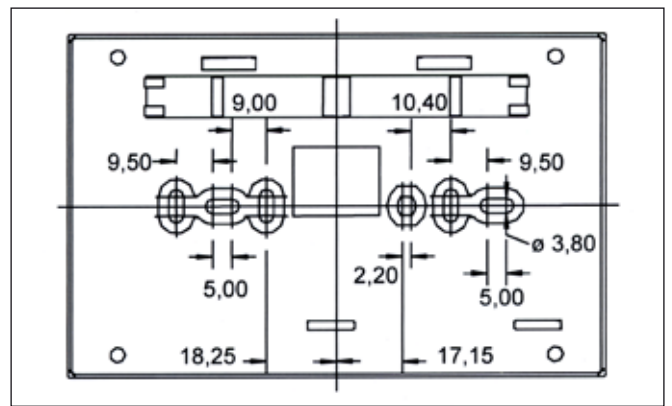
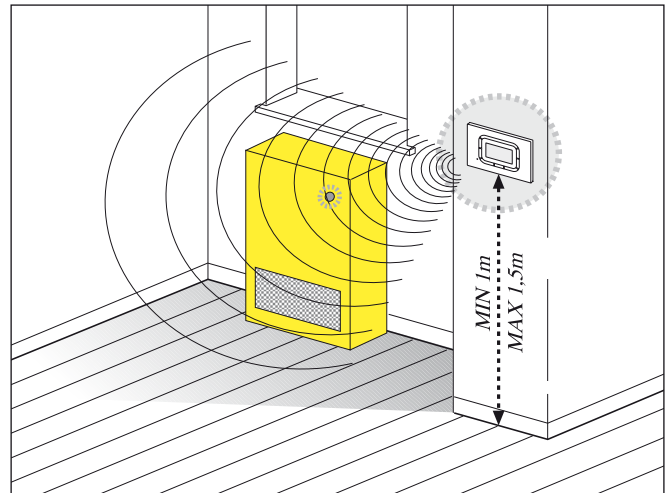

## EXTERNAL ACTIVATOR CONNECTION

The installation of a remote “dry contact” (telephone switch, room thermostat, Smart House, relay, etc.) must take place on the flame control board: D2, in particular on the bridge connected to contacts 3 and 7 (TR) using the faston plugs already connected. In particular, the open contact stop the appliance and the closed contact makes it work.

Warning!!! the opening or closing of the following contact is effective only if the appliance is powered and set in operating mode from command to the machine or from a wireless control.

**!** Use and connection of unsuitable equipment may damage the radiator irreversibly, therefore it is recommended this operation (connection) must to be done by a specialized technical personnel.

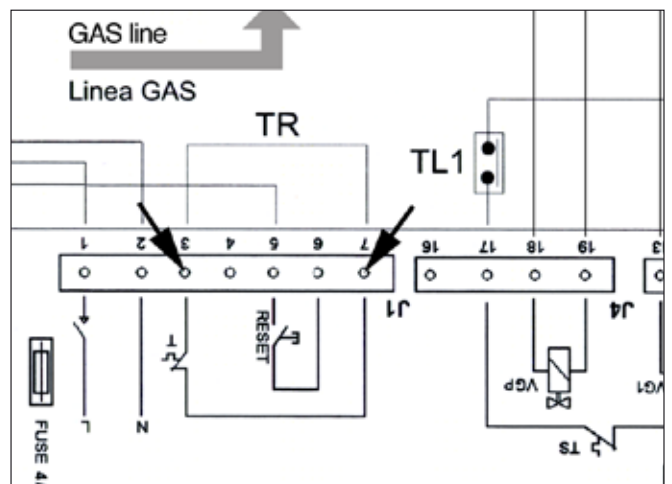

## MOUNTING THE "FLOOR STANDING" SUPPORT STRUCTURE

**!** **IMPORTANT!** Read and respect the general information of **INSTALLATION** chap.

The support structure kit is used when the wall selected for installation is unable to support the weight of the appliance. Thanks to this accessory, all the weight of the appliance is discharged onto the floor.

### Installation

- check the contents of the KIT;
- choose the installation wall and its actual consistency for making the hole (A) for the suction and exhaust pipes;
- assemble the side brackets (1) with the template (2) so as to create a single structure (5);
- move the single structure up against the wall and with the help of a spirit level, make the centre of hole (A);
- make the hole (A);

**Ø 65 mm hole for Ø 32 mm pipes or Ø 110 mm hole for Ø 54 mm pipes.**

- remove the plate (3) from the template (2);
- fit the unit (4) on the template (2);
- fit and fasten the pipes (10) on the unit (4);

#### Option A:

- fit the supports (6) on the side brackets (1), using the adjustment screws (7);

#### Option B:

- fit the optional base (8) on the side brackets (1);

- fit the new unit (structure + pipes) on the frame (11) of the appliance;
- move the appliance up against the wall and level;
- connect the power and gas supplies;
- fit the cover (9);

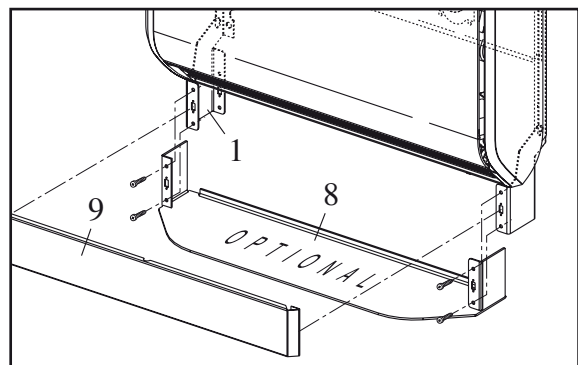
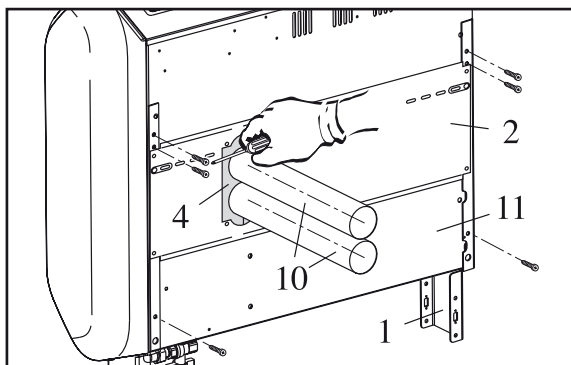
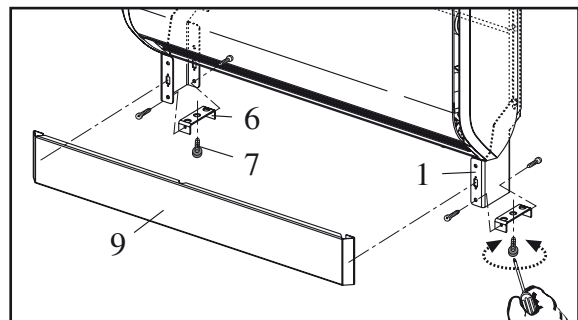
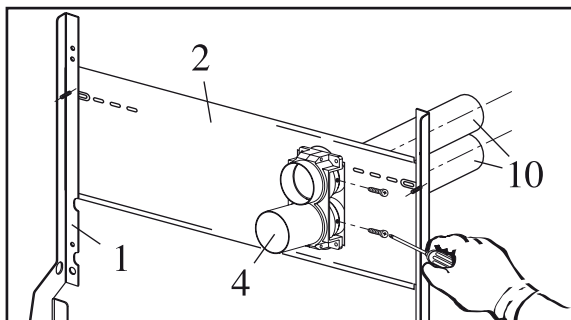
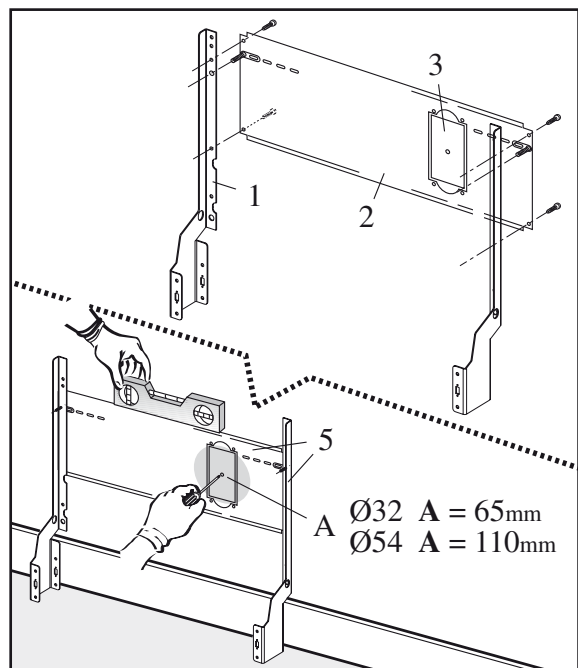

## PROTECTION FOR WALLS MADE OF WOOD PANELS

### FITTING SILUMINA FRAME ASSEMBLY FOR INSTALLATION ON COMBUSTIBLE OR WOODEN WALL

This assembly is suitable for walls between 100 mm and 500 mm thick.

- Having chosen the position for the heater in accordance with the installation booklet for the heater, cut a hole through the wall, with these dimensions: diameter (A).

The hole in the wall as neatly as possible to enable the flue assembly to be installed both straight and level through the wall.

- Fit the silumina frame assembly to the wall, as follows:  
1) Measure the wall thickness, not including the stainless-steel plate and cut the tube (2) to length equal to the wall thickness.

Fit the internal tube, (2) inside the opening cut in the wall. Fit the metal plate (5) to the inside of the wall, using the 4 screws with anchors for wooden walls provided, for fixing the plate on the wall. Fit the cut tube to the wall working from inside the building, ensuring that it fits within the lugs on the stainless-steel plate. Fit the internal wall plate so that the 4 screws (1) on it fit inside the tube.

2) Fit the external stainless - steel (3) AISI 304 to the outside of the wall using the 4 screws, included in the pack, if the external wall is hard stone chose screws and anchors suitable for stone walls.

Use a water resistant compound (e.g. Secomasic or Silastic) between the plate and the wall to prevent rainwater reaching the interior of the wall.

MOD.	Ø (mm)	A (mm)	L (mm)	
<b>3.0</b>	32	90	500	mm
<b>5.0</b>				
<b>7.0</b>	54	130	500	mm
<b>9.0</b>				

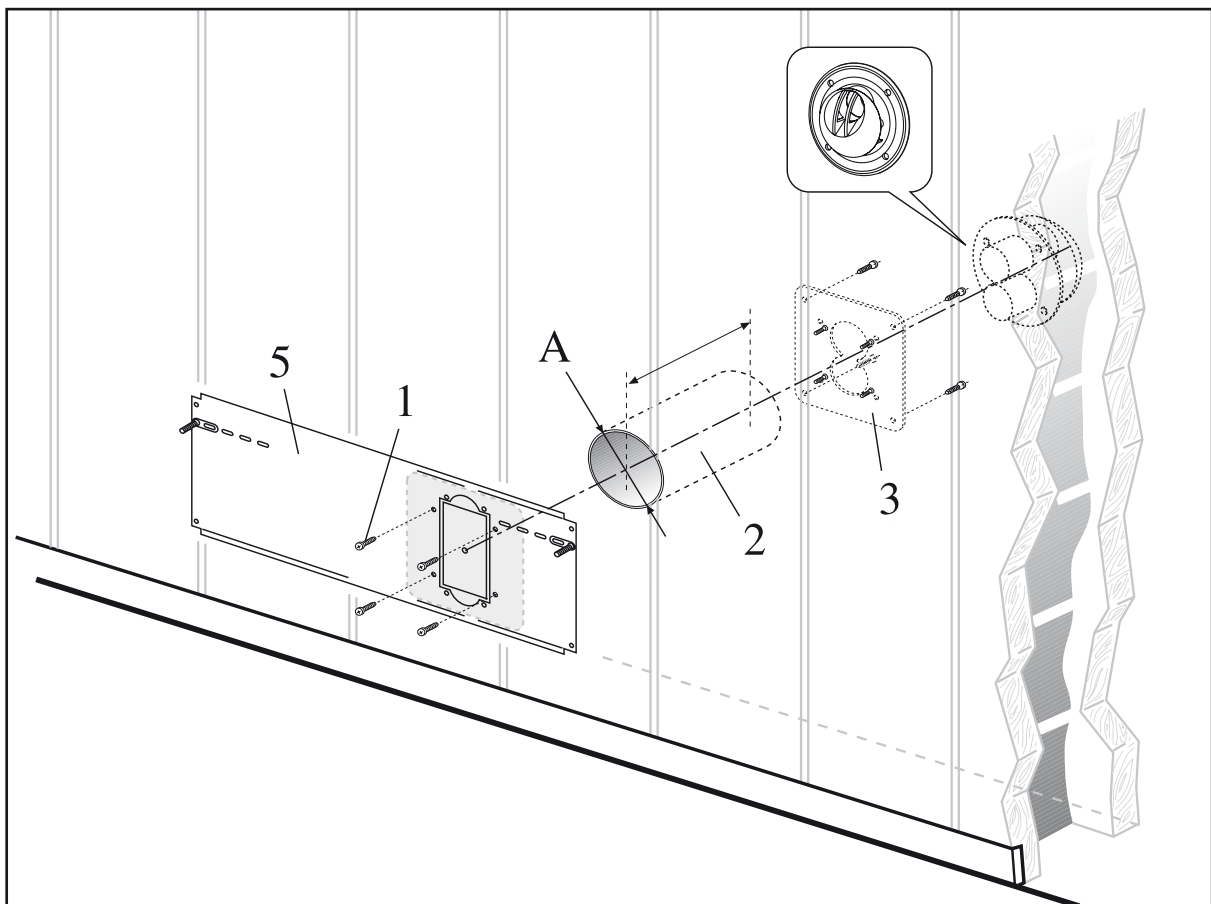

## POWER CONNECTIONS

The appliance must be installed by companies approved pursuant to Law. Upon completing the installation, such companies must issue a declaration of installation conformity in accordance with applicable national and local laws (see art. 17 of law no. 46/90) and the instructions provided by the Manufacturer in the installer's booklet attached to the product.

The appliances are fully wired in the factory and complete with plug for connection to the power mains. Only a HAR H05 RRF type power cable need be made with MIN cross section of 1 mm, using, for connection to the appliance, the socket provided and making an EARTH connection that is 2 cm longer than the PHASE and NEUTRAL leads. Connect the other end of the cable to a socket or omnipolar switch, in conformity with CEI standards, connected to an effective EARTH system.

 A proper earth connection is mandatory.

The manufacturer of the appliance cannot be held liable for any damage caused by lack of proper earth connection.

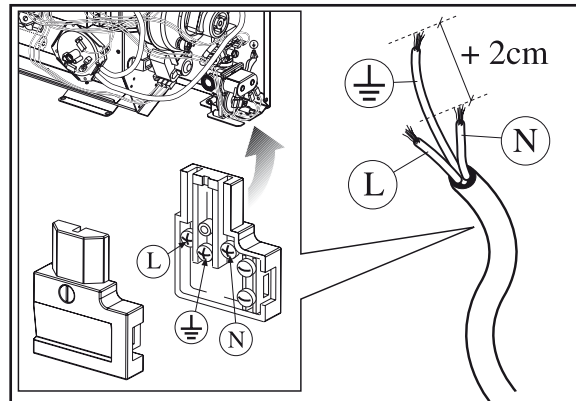

For jobs of an electrical nature, always refer to the diagram attached to this booklet.

Fit a disconnection device from the power mains upstream of the power cable (omnipolar switch or plug) such as to ensure a contact opening of at least 3 mm.

 Unsheath the EARTH lead so this is at least 2 cm longer than the other two leads.

 Never use gas and/or water pipes to earth the appliance.

## GAS CONNECTION

Check on the technical label that is on the heat exchanger cover, for the kind of gas that the appliance uses.

Use the proper gas tubes and pipe fitting. The etching under the appliance is a 3/8" M UNI ISO 7/1.

When the gas alimentation, is on the right side of the appliance for eventuating any problems use a nipples.

After the gas connection is done, do the first seal tests.

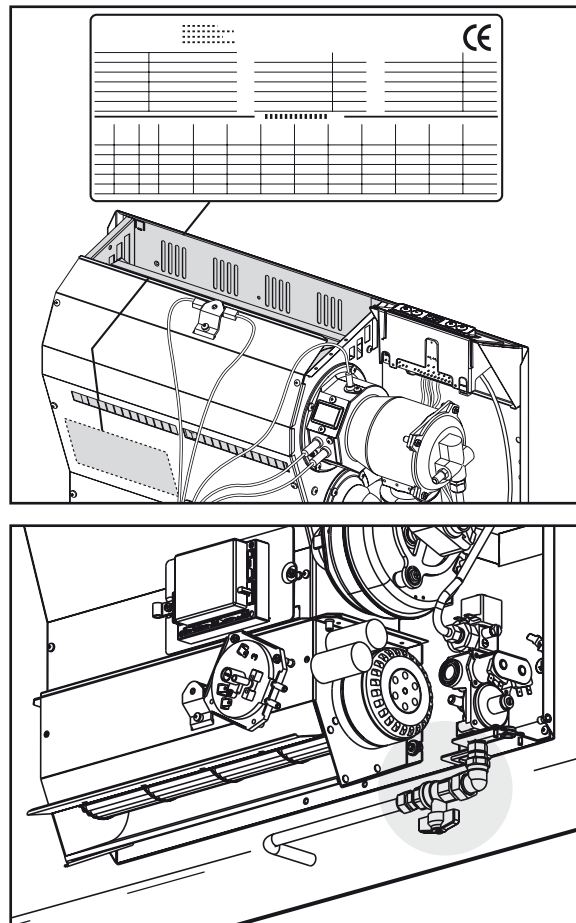

## PRELIMINARY OPERATIONS

The appliance is furnished and preset for the gas function (G 20) and regulated in factory.

Note: the apparatus can also be requested with the GPL gas function.

First things to do before you start the appliance check:

- If the appliance is preset for the right gas
- The gas connection is correctly realized and the gas switch is opened.
- The electrical connections are properly done.

 Remember it is also important to realize a good ground connection and to respect the neutral phase.

 **During the first start, could be emissions of vapors and odors annoying non dangerous. To avoid these inconveniences, it is recommended to run the unit at full power for several hours and ventilate the room.**

For greater comfort in the heated environment, we advise using the humidifier tray (1) encased in the casing.

 **Do not fill the tray to the top to prevent water overflowing with consequent damage to or malfunction of the appliance.**

 **Only fill the tray with water. Avoid all other liquids that could damage the tray or cause appliance malfunctions.**

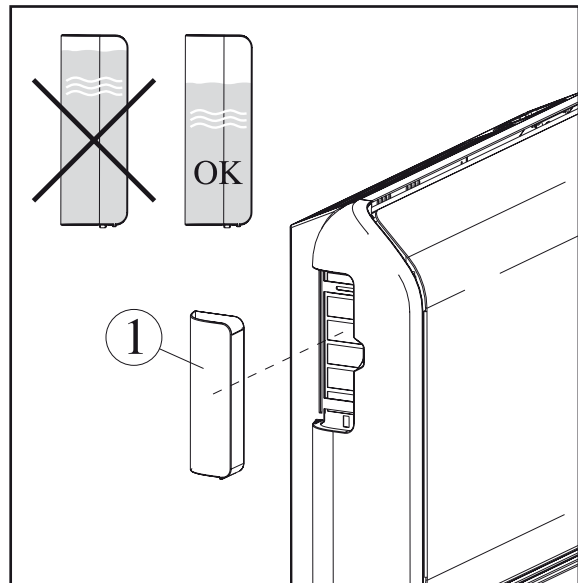

## FIRST SERVICE START

After performing all the preparation operations for initial start-up, to start the appliance:

- make sure the fuel tap is open;
- fit the plug in the socket on the appliance;
- move the master switch (if fitted) to "on" or fit the power plug in the wall socket;
- press the On/Off key (see User section) to switch on the appliance;
- set the room thermostat at a high value to reduce heating time;

After startup, the appliance runs until it reaches the set room temperature.

In case of malfunctions in startup procedure or operation, the appliance STOPS and the relevant unblock signal lights up on the display. Reset the appliance by keeping the unblock button pressed. Wait until the startup procedure is completed and the operation signal lights up.

- When the appliance is running, set the clock and the timer for automatic operation (see User section).

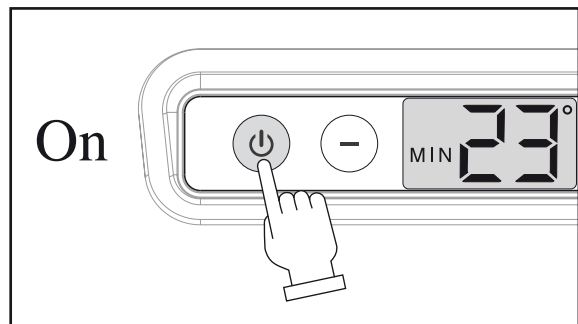
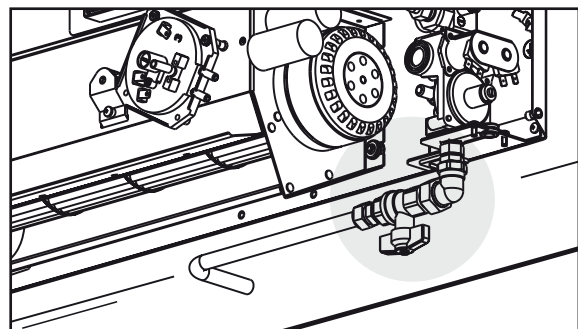
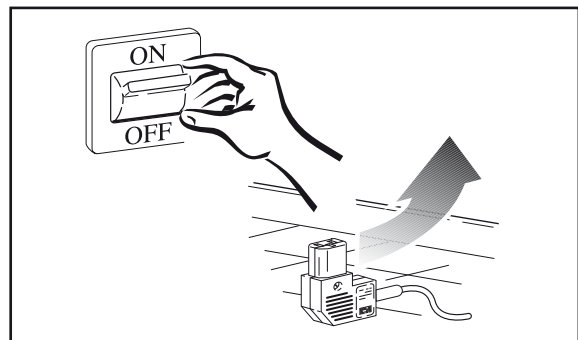

## PROCESSOR CONTROL BOX (P.C.B ASSY) MALFUNCTION

In case of any malfunctions in the control unit, RESET as follows:

- a - press the On/Off button as shown in the illustration.
- b - connect and disconnect the plug from the socket or move the master switch to "off" and then to "on".

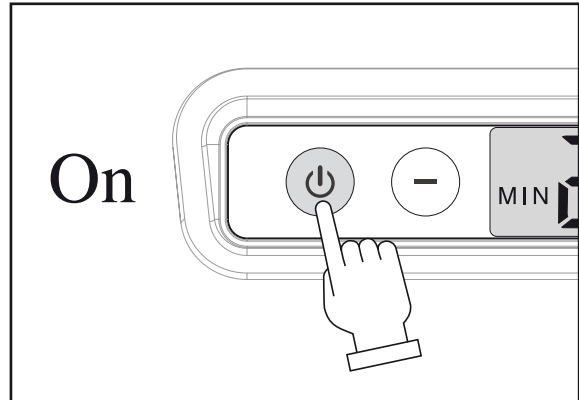

## CONTROLS DURING THE FIRST & AFTER STARTING SERVICE

-At the start verified that the gas pressures are as under the Table.

MODEL	G20 <i>nom. / verl.</i>	G30 <i>nom. / verl.</i>	G31 <i>nom. / verl.</i>	
<b>3.0</b>	12 / 7	29 / 15	29 / 15	mbar
<b>5.0</b>	12 / 7	29 / 15	29 / 15	mbar
<b>7.0</b>	12 / 7	29 / 15	29 / 15	mbar
<b>9.0</b>	11 / 6	29 / 15	29 / 15	mbar

- The gas pressure value has to be as in the table.
- The apparatus execute a stop, and next restart.
- Operating from the main control panel
- Operate on the atmospheric thermostat or the timer.

- The fan starts when thermostat gives the consent.

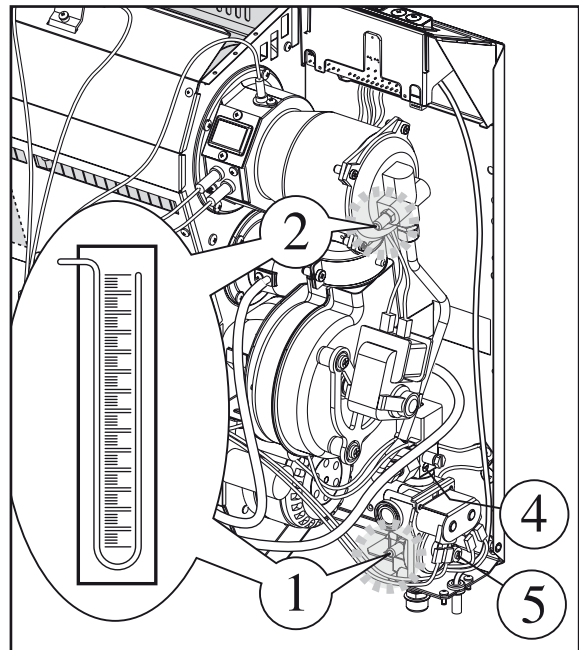

## GAS TRANSFORMATION

The appliance is preset for the methane gas (G20) following the technical label, but you can change at GPL (G30/G31) with the transformation that is furnished.

The transformation has to be done only by Technical Service Assistance, the manufacturer or by authorized persons even if appliance has been already installed.

Shut down the appliance with the main button, and then disconnect the electrical plug.

Proceed to the disassembling of the cover (1) like explained in the chapter assembling & disassembling the cover.

### Sequence apparitions

- To make the transformation you have to disconnect the gas from the nipples R3/8 (1) that is on the cap.
- Take off the screws M5 (2) then slip off the cap and the burner group (3).
- Unscrew the screws (4) and the burner (5).
- Unscrew the 3 injectors (6) change them with the new ones. Be real careful when you fasten the injector, check on the injector that it has the right values as in the table.
- The injectors seal and the nipples 3/8", are realized mechanically so you don't need a gasket.

-Verifying that the values on the nozzles ore as in the table below.

MODEL	mm	METHANE	Propane
<b>3.0</b>	∅	0,82	0,47
<b>5.0</b>	∅	1,10	0,63
<b>7.0</b>	∅	1,33	0,78
<b>9.0</b>	∅	1,50	0,85

-Reassemble the cap with the burner, in the same way that you dissembled don't forget the O-ring (7) that goes around the cap.

-Proceed to the regulation as indicated in the Cap. Regulation; verified the tubes gas connections capacity that goes from the gas valve to the burner.

-Change the gas labels; seal the parts that you made the regulation, after the transformation. Don't forget the old labels on the apparatus because it will cause problems or danger.

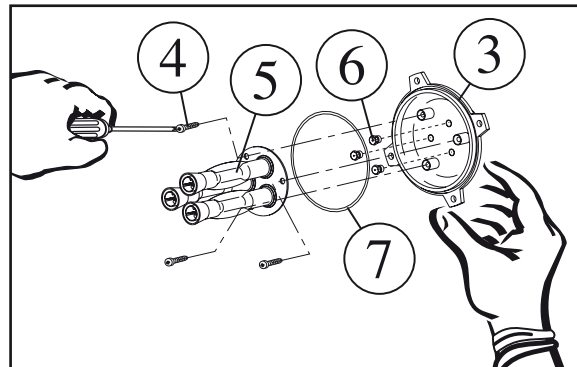
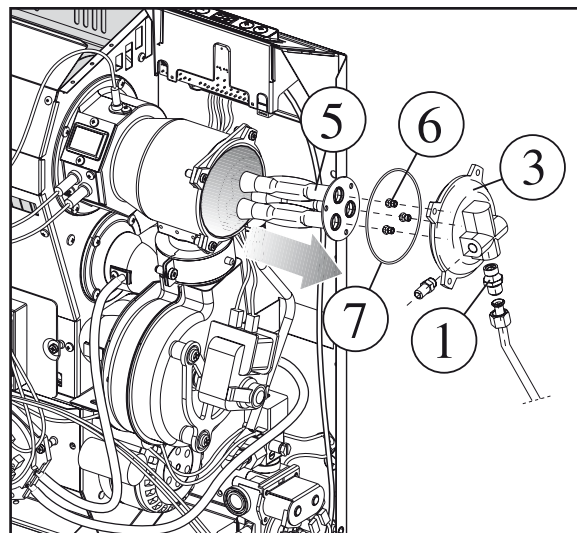
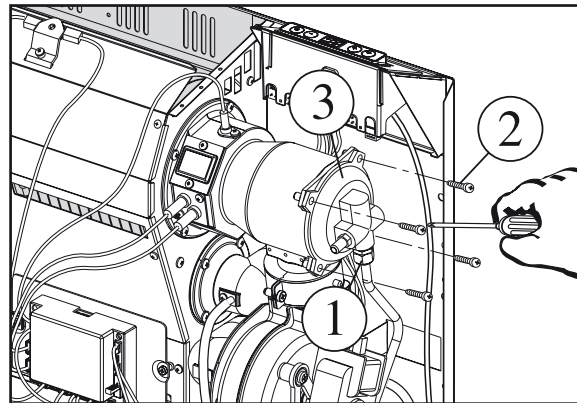
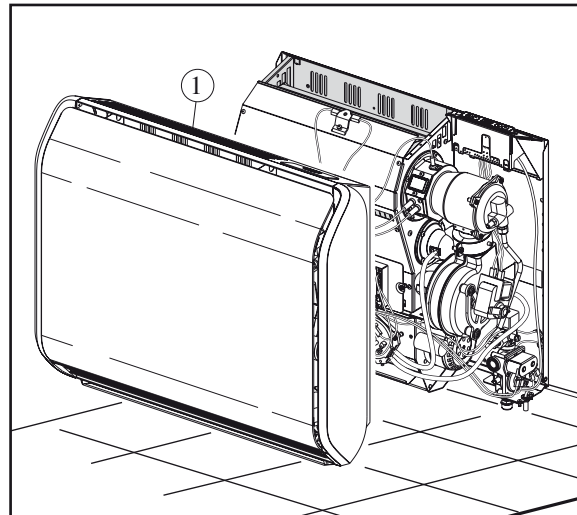

The appliance is furnished with (G20) gas function following the Technical label, and the constructor already regulates it. If you make a new regulation, like exchanging the gas valve, or a gas transformation from Methane to GPL or reversed, this regulation has to be done from a Technical service Assistance or by the manufacture

**Gas methane G 20(20mbr); nominal & minimum pressure regulation.**

- Open the gas tap put the electrical plug under the appliance then pushes the start button and put to the max power.

*Alimentation pressure*

- Loosen the pressure screw (1) connect the manometer and verified the pressure value is included between 17/25mbar (like indicated in the table) then close the screw after that the manometer tube is pulled away.
- Loosen the pressure screw (2) connect the manometer verified the nominal and minimum pressure values are as specified in the table.

*Nominal pressure*

With the appliance in function at a max power loosen the outlet pressure screw (2) then connect the manometer and verified that the nominal pressure values are as specified in the table (Nozzle Pressure). In the GPL function, only for the 3+ categories the regulator has to be out of service fastening clockwise the adjustment screw (1) at an immediately inferior value to the alimentation max pressure.

At verification done, take away the manometer and fasten the screw.

*Minimum pressure*

- disconnect the power supply from the appliance.
  - behind the control with display, change the position of the jumper JP1(the closer to fuse) covering the pins, so to force the appliance to operate at "reduced power".
  - connect the power supply to the appliance
  - act on the idling screw (4).
- Turning the screw in the ANTI-CLOSED direction to rise up the pressure , on the contrary, rotating in the CLOCKWISE direction, the pressure will decrease.
- once the adjustment has been completed: disconnect the power supply from the appliance before to put the jumper in its original position , disconnect the pressure gauge from the pressure socket and close the pressure reading screw.
  - once the adjustments have been completed, seal the modulator screw and the regulator screw with a drop of paint.
  - disconnect the pressure gauge from the pressure socket and close the screw.

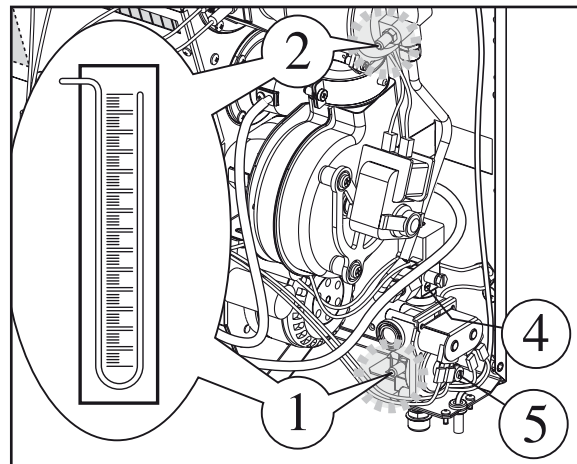

MODEL	G20	G30	G31	
	nom. / verl.	nom. / verl.	nom. / verl.	
<b>3.0</b>	12 / 7	29 / 15	29 / 15	mbar
<b>5.0</b>	12 / 7	29 / 15	29 / 15	mbar
<b>7.0</b>	12 / 7	29 / 15	29 / 15	mbar
<b>9.0</b>	11 / 6	29 / 15	29 / 15	mbar

**Regulation GPL butane G30 (29mbar) and Propane G31 (37mbar). Minimum and nominal pressure.**

- Open the gas taps put the electrical plug under the appliance then push the start button and put to the max power.

*Alimentation pressure*

- Loosen the pressure screw (1) connect the manometer and verified the pressure value is included between 29 mbar with the Butane and 37 mbar with Propane then close the screw. In the case that the net pressure is low, operate on the low-pressure regulator that is put on the Gas tank.

- Verified that the establishment GPL vaporization capacity is sufficient.

*Nominal pressure*

With the appliance in function at a max power loosen the outlet pressure screw (2) then connect the manometer and verified that the nominal pressure values are as specified in the table (Nozzle Pressure). In the GPL function, only for the 3+ categories the regulator has to be out of service fastening clockwise the adjustment screw (1) at an immediately inferior value to the alimentation max pressure.

At verification done, take away the manometer and fasten the screw.

Whenever the apparatus is going to be regulated at pure Propane, to avoid heat exchanger overheating, is necessary knowing that you are using the proper gas, but if you use a un proper gas like a mixture of Propane/Butane or pure Butane you might have problems.

#### *Regulation min pressure*

Proceed to the minimum pressure regulation after that you regulated the max pressure!  
To make a regulation operate on the screw that is on

the modulator body (4).

Rotating the regulator screw (3) clockwise the pressure decrease, rotating counter clockwise the pressure increases.

#### **Compensation PROBE Room Thermostat**

This feature allows you to compensate for the difference between the temperature measured at the point where there is the sensitive element of the room temperature sensor and the temperature being that you want to have in the room (see sec. USER).

## ORDINARY MAINTENANCE

The appliance maintenance is important for the efficiency and the reliability of the radiator. We recommend that Technical Service Assistance perform the maintenance once a year.

#### *Preliminary operations:*

- Disconnect the electrical alimentation taking off the electrical plug from the apparatus otherwise; place the wall switch to the "off" position.
- Close the gas tap.
- Wait that the appliance gets cold completely.

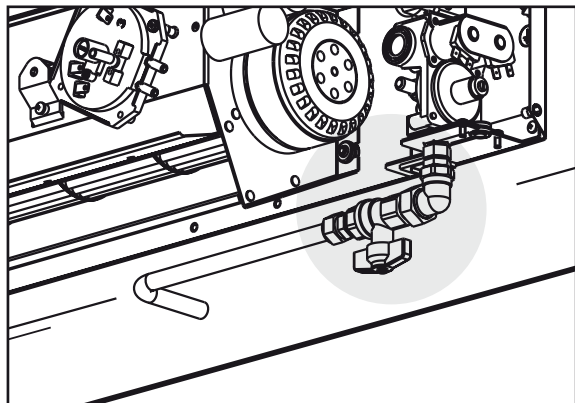
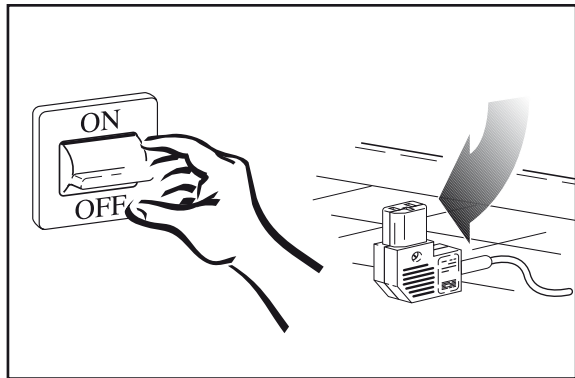

## APPLIANCE CLEAN OUT

#### *Cover clean*

The only cleaning that is required by the owner, involves removing the cover, and wiping it clean the dust, which may have collected.

Do not put grease or lubricants on any parts of the appliance.

To clean plastic or painted parts don't use any product that will cause damage to the apparatus.

It is important that the switch is turned to the "off" position on the control panel. Position the wall switch on off. Wait that the appliance gets cold completely

Do not allow water or any other liquid to be applied directly to the cover, uses dampened clothes to do the operation that you want.

#### *Internal clean*

For the correct disassembly and assembly see in the relative section.

#### *Burner clean out*

If you want a good burner clean, especially if the appliance has been working in dirty.

Places, or it didn't work at all, use the compressor to blow next to the injector; it will come out all the residues and the impurity caused from the burner. Check all the injectors if are good.

**Don't use metallic utensil.**

### Cleaning Electrode

The ignition electrode (1) and revelation (2) have to be cleaned very carefully, after a period of time they get fragile because of the work they have to perform.

- Unscrew the screws (3 o 4) and extract the electrode group (1 o 2) using a little brush with metallic hair for cleaning, after insert the electrode group (1 o 2) if necessary exchange the seal gasket (5) be real careful to not damage the electrode.

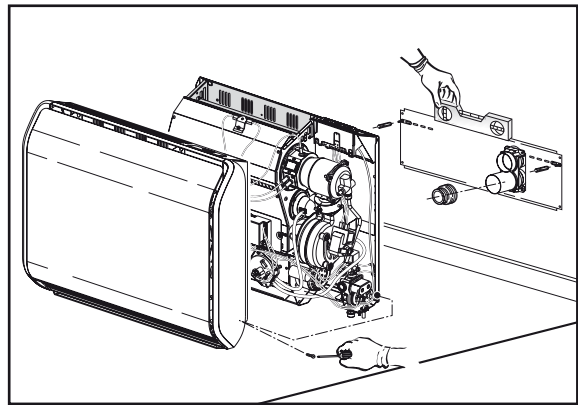

### Pressure switch tubes

Check if there are deposits or condensation within the pipes pressure measurement:

- Fan combustion air pressure switch.
- Exhaust fumes / pressure.

Blow, disconnect the switch and test it, otherwise, may be damaged.

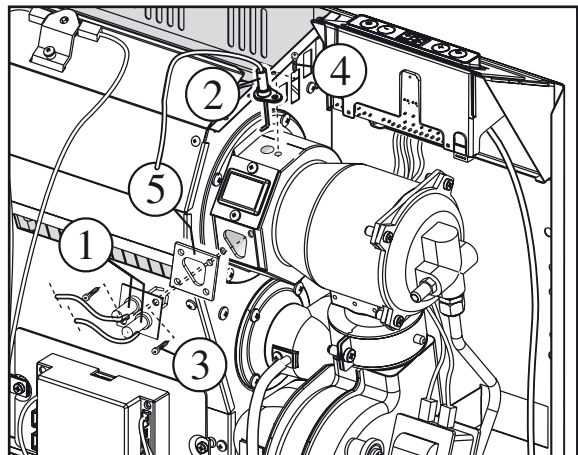

## COMPONENTS REPLACEMENT

### Preliminary operations:

- Disconnect the electrical alimentation taking off the electrical plug from the apparatus otherwise; place the wall switch to the "off" position.
- Close the gas tap.
- Wait that the appliance gets cold completely.

### Replacing the Control board with Flame Control

To remove and refit the Flame Control board (1), follow the instructions below:

- loosen the retention screw (2) of the board cover;
- remove the connectors from their plugs;
- completely replace the electronic board, taking care to reconnect all the wires properly.

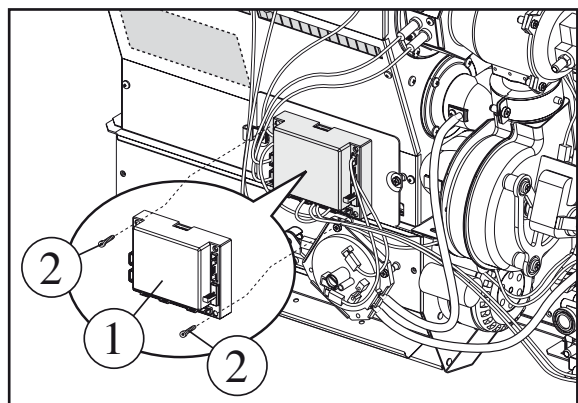



### Electrodes replacement

Follow the indication to replace the electrode.

- The ignition electrode (1) and revelation (2) half to be cleaned real carefully, after a period of time they get fragile because of the work they which they do.
- Take off the high-tension cable
- Unscrew the screws (3 o 4) and extract the electrode group (1 o 2)
- Reassemble the electrode (1 o 2) with the reversed sequence of the assemblage replace the seal gasket (5) be real careful at not damage the electrodes ceramic insulator.
- Reconnect the cables on the processor control box (P.C.B assy) (6).

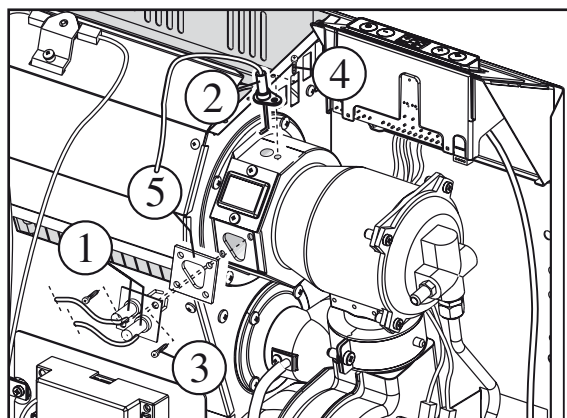

### Replacing the safety thermostat (manual resetting)

Follow the instructions below to remove and refit the thermostat (3):

- remove the thermostat retention bracket (1) by loosening the screw (2).
- disconnect the power connectors from the Safety thermostat (4).
- refit the thermostat unit in reverse fitting sequence.

The safety thermostat trips if the convection fan is not working properly or anomalous overheating occurs and/or the outflowing air temperature reaches over 107°C, disengaging the burner, closing the gas valve and stopping the appliance.

In case of part replacement (electronic boards, valves, thermostats, pressure switches, fans, etc.), only use the Manufacturer's Original Spares.

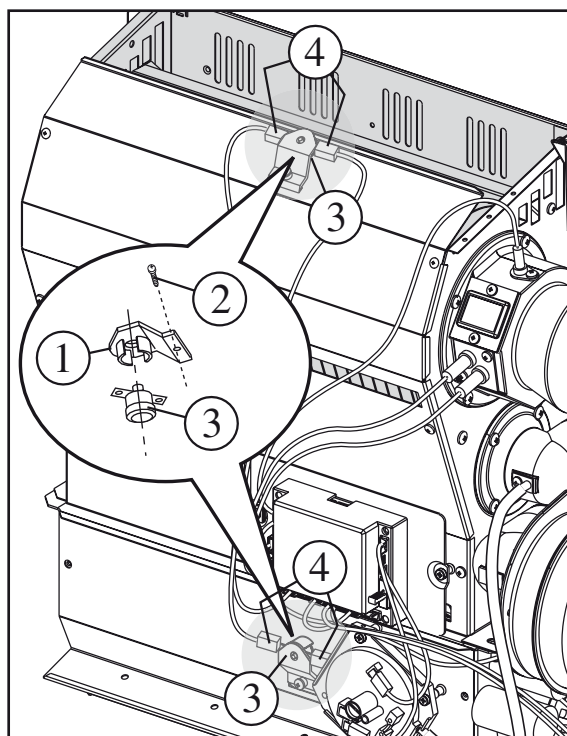

### Valve gas coil replacement

- Follow the indication to replace valve gas coil:
- Unscrew the screws that hold the stirrup (4) that block the coil (1) at the valve body (2) and replace.
- Extract the fail-soft coil (1) taking it out real careful.
- Replace the new fail-soft coil (3) putting in the right position
- 4 replace the flask (4) to stop the coil.

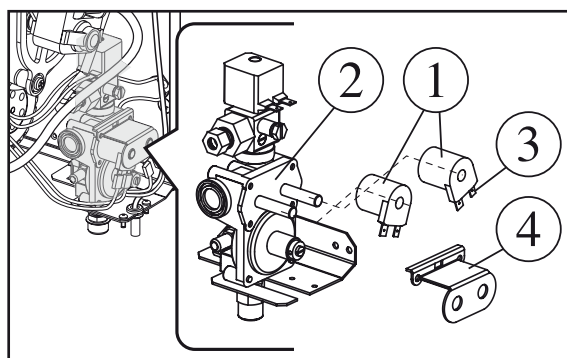

### Coil modulator replacement

- Follow the indication to replace *coil modulator*.
- remove the electrical connections.
- unscrew the nut (1) attachment that locks the reel (2) the valve body (3) and remove it.
- remove the faulty coil (2), pulling it carefully.
- reinsert the new coil, taking care to position it correctly.
- replace the electrical connections.

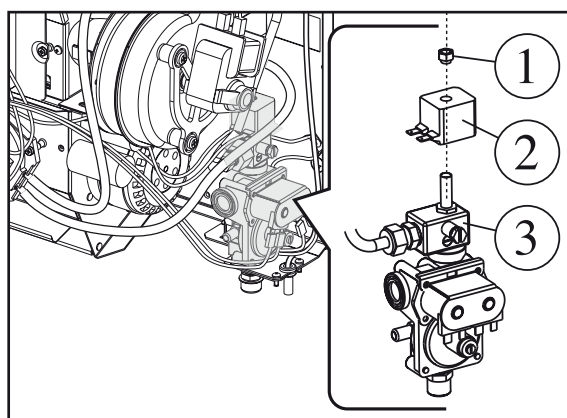

### Replacing the gas valve

Follow the instructions below to remove and refit the valve:

- remove the power connections.
- loosen the retention nut that secures the burner pipe (1) to the valve body (2).
- loosen the retention nut that secures the mains gas pipe (3) to the valve body.
- loosen the retention fork screw and remove it.
- remove the faulty valve by sliding off carefully.
- fit the new valve, being careful to position this correctly.
- fit the power and gas connections back on.

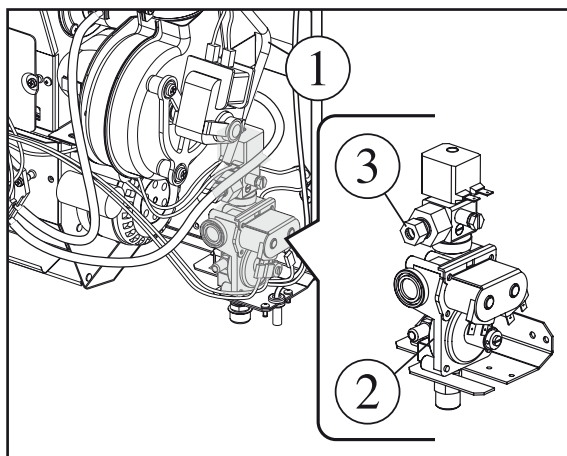

### Pressure switch replacement

Follow the indication to replace the Pressure switch

- Extract the pressure switch (1) from support (2)
  - Take off the tubes (3 & 4) and the electrical connectors from the pressure switch.
  - Unscrew the stirrup support fixing screw (2) separating the pressure switch from the frame.
  - Reassemble the new pressure switch
  - Insert the silicone tubes (3 & 4), also be real careful when you reconnect the cables, if you are not sure of what you are doing look at the electrical diagram.
- Always remember, to use original spare parts.

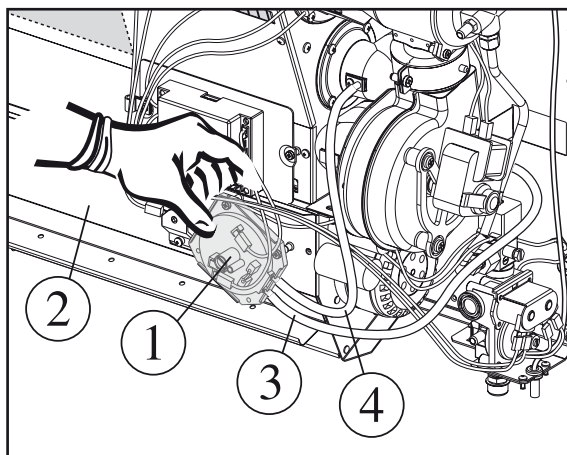

### Replacing the condenser (model 50, 70 and 90 only)

Follow the instructions below to remove and refit the fan condenser:

- take out the damaged condenser (1)
- replace the component part and fit it back, performing removal operations in the opposite sequence.

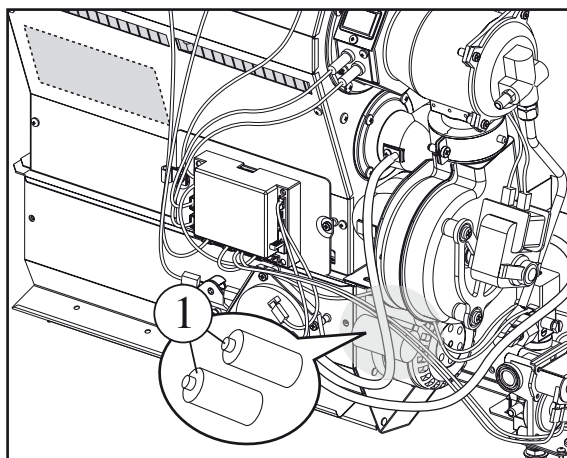

## DISASSEMBLY & RIASSEMBLY OF THE CASING

### Disassembly cover

- Disassembly the casing;
- Remove the cup (3);
- Unscrew the screw (2);
- Remove the outside skirt (1) completely;
- To replace the skirt do the reversed sequence.

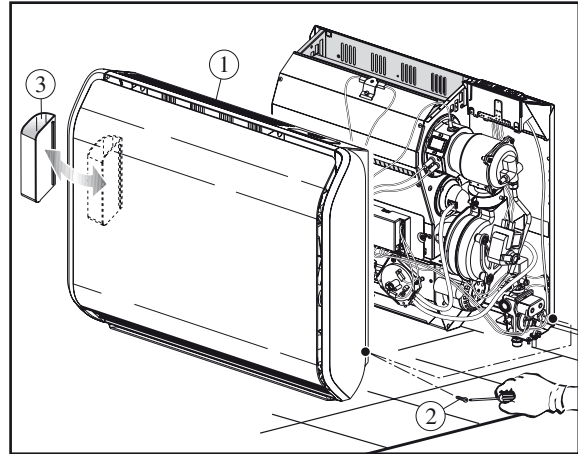

## EVENTUAL ANOMALY

FAULT	CAUSE	REMEDY	
The appliance does not start	Power supply disconnected /	Check.	
	Incorrect gas pressure	Set correct pressures	
	Thermostat fails to engage	Adjust the thermostat	
	No signal from pressure switch.	Check/Replace: - not suitable pipes (diameter, length, curves, fitting) - pressure switch (operation/connections) - small pipes (cleaning) - centrifugal fan (connection/operation).	
	Burnt-out fuse	Replace	
	Control board faulty	Replace	
	High room temperature	Room thermostat set too high.	
	Air in gas pipes	Bleed	
	The appliance fails to start (appliance not working properly / blocked)	Incorrect ignition electrode distance	Reset the correct distance
		Nozzles dirty	Clean nozzles
Installed nozzles not suitable for gas used		Fit right nozzles	
Control board faulty		Replace	
Gas valve closed		Check / Replace: - Safety thermostat tripped (tang. fan or faulty thermostat, gas setting) - Valve faulty	
The timer does not engage or does not work	Wireless synchronization inactive	Synchronize the Wireless	
	Wrong programming	Adjust the program.	
	Wrong function programming	Position on "AUTO"	

FAULT	CAUSE	REMEDY
The thermostat does not engage.	Thermostat programming wrong	Adjust thermostat: - increase - decrease.
	Unfavourable Wireless or appliance position.	Change position
	Upper or lower grille blocked	Clean / Free
	SPLIT probe has come out of seat.	Position correctly
	INTEGRATED room probe faulty	Replace Wireless
No spark at ignition	Ignition electrode/detection unit faulty, earthed or badly connected	Check / Replace
	Flame control board faulty	Check / Replace
The burner switches off during operation	Not enough gas pressure or pressure incorrect.	Check/Adjust gas
	Inlet and exhaust pipes fitted badly	Check / Reset: - pipe length - appliance / pipe seal
	Inlet/outlet diaphragms not installed	Fit diaphragms
The appliance fails to heat properly	HEATING programming set at MIN.	Set at MAX.
	Gas/nozzle pressure below par.	Check and regulate the gas / replace.
	Power of appliance not enough for installation premises.	Replace the appliance with a more powerful one.
The centrifugal fan does not work	Faulty control board.	Replace
	Faulty motor	Replace
	Faulty pressure	Replace
The tangential fan does not work	Faulty control board.	Replace
	Faulty motor.	Replace
Reduced hot air flow	Faulty tangential fan.	Replace
	Inlet / outlet grille blocked.	Free
Fan does not switch speed	Faulty flame control board.	Replace
Burner does not switch power	Digital Chronothermostat faulty.	Replace
	Faulty flame control board.	Replace
	Faulty gas valve.	Replace
	Faulty/wrong cables.	Replace/ set correctly.
Digital control display switches off (also with buffer batteries)	Batteries discharge	Replace
	Faulty Wireless	Replace
Vibrations between combustion engine and aluminium pipe section	No vibration-damper sleeve	Fit vibration-damper sleeve





**ITALKERO S.r.l.** . via Lumumba 2 . Zona Ind. Torrazzi . 41122 Modena . Italy . Tel +39 59 2550711 . FAX +39 059 4900500 . [www.italkero.it](http://www.italkero.it)

NOTA: Nel continuo perfezionamento del prodotto, le caratteristiche estetiche e dimensionali, i dati tecnici, gli equipaggiamenti e gli accessori, possono essere soggetti a variazione.

NOTE: Due to ongoing product upgrading, aesthetic and dimensional features, technical details, fittings and accessories could undergo changes and are not binding.

NOTE : En vue de l'amélioration continue des produits, les caractéristiques esthétiques et de taille, les données techniques, l'équipement et les accessoires peuvent être modifiés.

HINWEIS: Im Bestreben unsere Produkte kontinuierlich zu verbessern, können maßbezogene und ästhetische Eigenschaften, technische Daten, Ausrüstungen und Anlagen sowie Zubehörkomponenten Veränderungen unterworfen sein.