



# Italkero

*Wall gas stoves*  
**- NATURAL -**



SC



SV, SE

Eco  
**SC - SV - SE**

**INSTALLATION AND  
AFTER-SALES SERVICE**

CE

0476  
CR1228

## CONFORMITY

Our equipment is conforming with:

- Gas Directive 2009/142/EC (ex. 90/396/EEC)
- Electromagnetic Compatibility Directive 2004/108/EC
- Low Voltage Directive 2006/95/EC



## RANGE

model	description	code
SC 18	PIEZO without timer, without fan, methane	SC18TC M0000
SC 30	PIEZO without timer, without fan, methane	SC30TC M0000
SC 45	PIEZO without timer, without fan, methane	SC45TC M0000
SV 18	PIEZO without timer, with fan, methane	SV18TV M0000
SV 30	PIEZO without timer, with fan, methane	SV30TV M0000
SV 45	PIEZO without timer, with fan, methane	SV45TV M0000
SE 18	ELECTRONIC without timer, with fan, methane	SE18T2 M0000
SE 30	ELECTRONIC without timer, with fan, methane	SE30T2 M0000
SE 45	ELECTRONIC without timer, with fan, methane	SE45T2 M0000

NOTE: all our equipment is also available LPG versions.

*Dear technician,*

*We thank you for choosing this convection heater product. We can assure you its performance will be long lasting, reliable, efficient and safe in use.*

*This booklet includes the information required to install it safely, as a supplement to your technical qualifications.*

*Best regards,*

*The Manufacturer*

---

## WARRANTY

The convection heater comes with a MANUFACTURER'S WARRANTY which runs from the date of certification by your local Technical service (see our website for contact information).

We invite you to apply to the above-mentioned Technical service that with no payment will:

- commission your convection heater.
- Ratify the WARRANTY CERTIFICATE furnished with the appliance; we suggest you read the certificate carefully.

## GENERAL

General warnings	5
Basic safety rules	5
Description of the appliance	6
Identification	6
Structure	7
Technical data	8
Electrical scheme	9
Control panel	11

## INSTALLER

Receiving the product	13
- Weight and dimension	14
Installation	15
- Positioning the appliance	15
- Wall mounting	16
- Installing the template and bracket	16
- Fumes / air pipe assembly and gas connection	17
- Assembling the convection heater	18
Electrical hookup	19
Gas hookup	19

## TECHNICAL SERVICE

Preliminary operations	20
Commissioning	20
Malfunctions	21
Check during and after commissioning	21
Changing the gas type	22
Adjustments	24
Routine maintenance	25
Cleaning the convection heater	26
Replacing components	27
Removing and restoring the jacket	31
Troubleshooting	32
Useful information	36
Notes	37

*In same parts of the book there are used these symbols:*







**Attention:** it used to underline particular caution or actions.









**Prohibited:** it used to underline the actions that don't half to be executed.

## GENERAL WARNINGS

-  Remove the packaging and check that the contents are present and correct. If any parts are missing, contact your reseller.
-  The convection heater must be installed by a technician qualified pursuant to Italian Law 5 March 1990 n° 46, who will issue a declaration of conformity with the installation regulations and instructions provided by the manufacturer in the included booklet.
-  The convection heater must be used for the purpose specified by the manufacturer. The manufacturer is not liable in anyway for damage or injury to persons or animals resulting from incorrect installation, adjustments or improper use of the appliance.
-  If the convection heater is not used for a long time, the following procedure must be completed:
  - set the appliance's master switch to OFF;
  - set the master switch of the installation (if present) to OFF or pull its power plug;
  - close the gas supply cock.
-  This booklet is an integral part of the appliance and must be kept carefully and ALWAYS accompany the convection heater when it is handed on to another user or installed in another system. If it is damaged or lost, please request a new copy from your local Technical Service.

## BASIC SAFETY RULES

Certain basic safety rules apply to the use of electrical and fuel/gas powered equipment, as follows:

-  Do not allow children or unsupervised disabled persons access to the convection heater.
-  Do not use electrical equipment such as switches, domestic appliances, etc. if you detect a fuel/gas leak or combustion fumes in the room. Should you do so:
  - ventilate the room by opening the doors and windows;
  - close the fuel/gas supply cock;
  - contact Technical Service or a qualified technician immediately.
-  Do not touch the convection heater when barefoot, or when wet.
-  Before cleaning the convection heater, shut off power to it by setting the installation's master switch to OFF or pulling the power plug.
-  Do not pull, take apart, or twist the electrical cables running from the convection heater, even if when they are disconnected from the mains. Do not place towels, dishcloths, doilies or any other such objects on the convection heater; they can cause malfunctions or even serious danger.
-  Do not dump or abandon the packaging material (cardboard, staples, plastic bags and so on) within the reach of children, as they pose a serious health hazard.
-  Do not leave the packaging material within the reach of children - doing so is extremely dangerous.

## DESCRIPTION OF THE APPLIANCE

Convection heaters are standalone gas powered room heaters. They have an atmospheric burner with TYPE C combustion chamber which is sealed off from the room to prevent hazardous fumes and gas returning to the inhabited area.

The combustion air and flue gas are taken from and discharged outside the room via two concentric pipes, exploiting the balanced upwards draught of the combustion fumes.

Given their small size, they can be installed even in restricted spaces. They are equipped with a humidifier tank to optimise comfort in the heated room.

**They are factory equipped for METHANE operation, but can be adapted to operation with LPG (G30/G31) with the included kit of nozzles.**

**Note: The appliance can be supplied already adapted to LPG operation on request.**

**SC/SV** - The thermostatic ignition/control/regulation valve, controls all main functions and automatically shuts off the gas supply in case of malfunction.

The control panel allows you switch on the appliance's electrical power (appliances with tangential fan or timer only), to start and stop it manually or automatically using the timer, to set its heating power and start/stop the fan, adjust the room temperature setting and restore operation after a malfunction.

**SE** - The heat exchanger, which is made of die cast aluminium and with fins, assures highly efficient combustion. The tangential fan rapidly heats the room when heating is required.

The appliance is controlled by an electronic controller which automatically shuts off the gas supply in case of malfunction.

The control panel allows you switch on the appliance's electrical power, to start and stop it manually or automatically using the timer, to set its heating power and start/stop the fan, adjust the room temperature setting and restore operation after a malfunction.

## IDENTIFICATION

The convection heater can be identified by:

- its packaging label:  
this gives the product name, code, serial number and gas type.

- nameplate  
this gives the serial number, model and main technical data.

- gas type label:  
Gives the appliance's gas type; it must be replaced with the appropriate new label if the appliance's gas type is changed.

 **Spare parts and service can only be provided if the model of the appliance is properly specified. Tampering with, removing or losing the nameplate means that the appliance cannot be properly identified, and makes it very hard to safely install or service the appliance.**

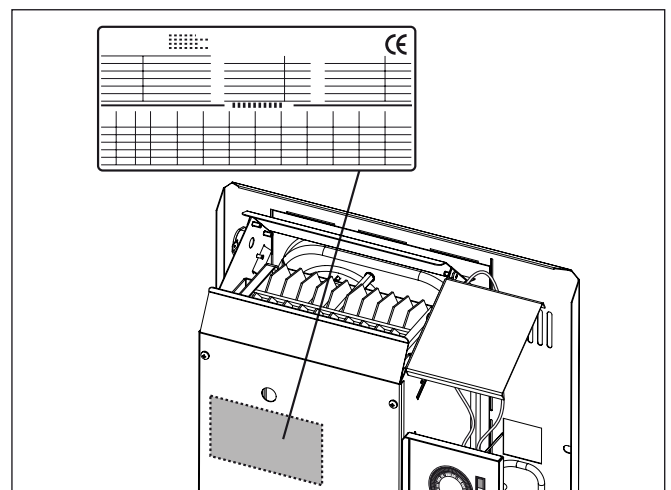
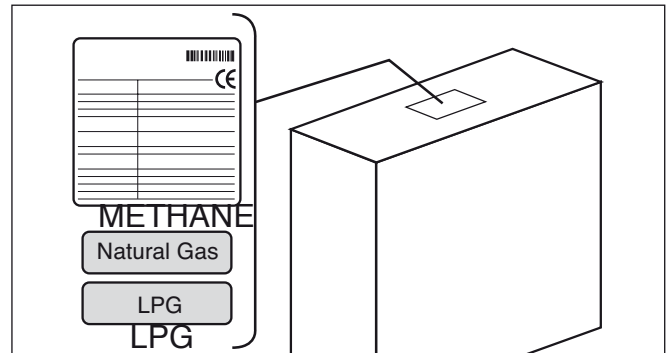

SC

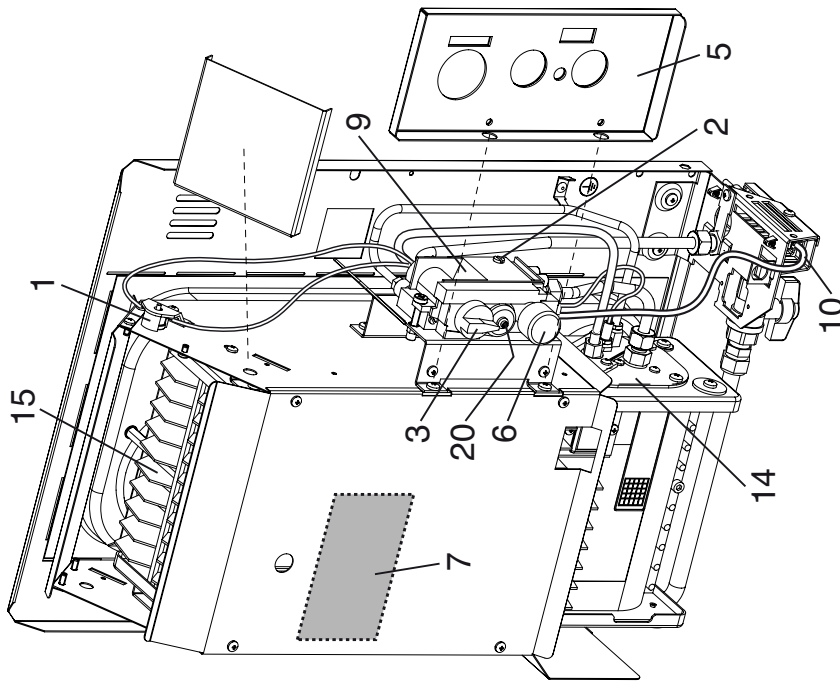

- 1 - safety thermostat
- 2 - MIN pressure adjuster screw
- 3 - ON/OFF knob
- 4 - timer
- 5 - casing
- 6 - room thermostat
- 7 - nameplate
- 8 - fan switch (ON/OFF)
- 9 - gas valve
- 10 - room thermostat sensor

SV

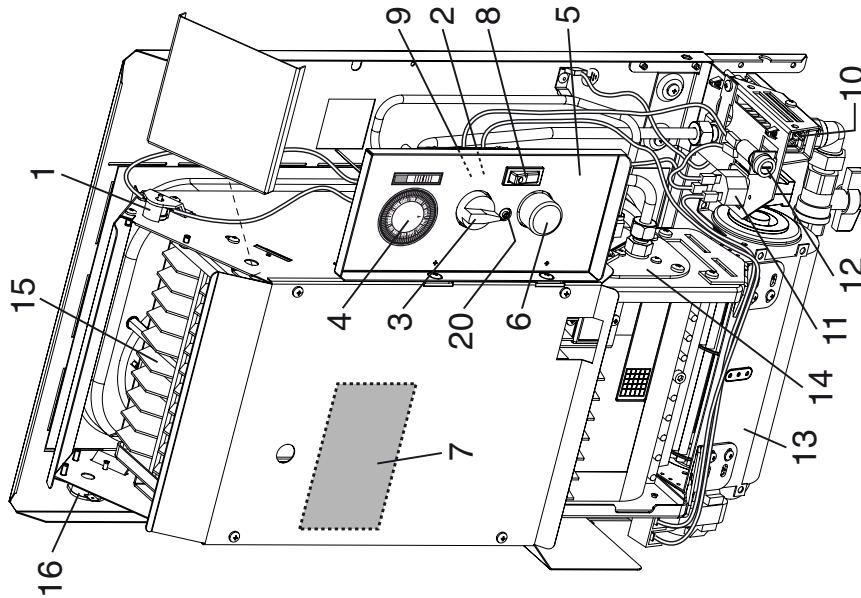

- 11 - power plug
- 12 - power fuse
- 13 - tangential fan
- 14 - burner unit
- 15 - heat exchanger
- 16 - tangential fan thermostat
- 17 - controller
- 18 - MIN adjuster screw
- 19 - MAX adjuster screw
- 20 - MAX pressure adjuster screw

SE

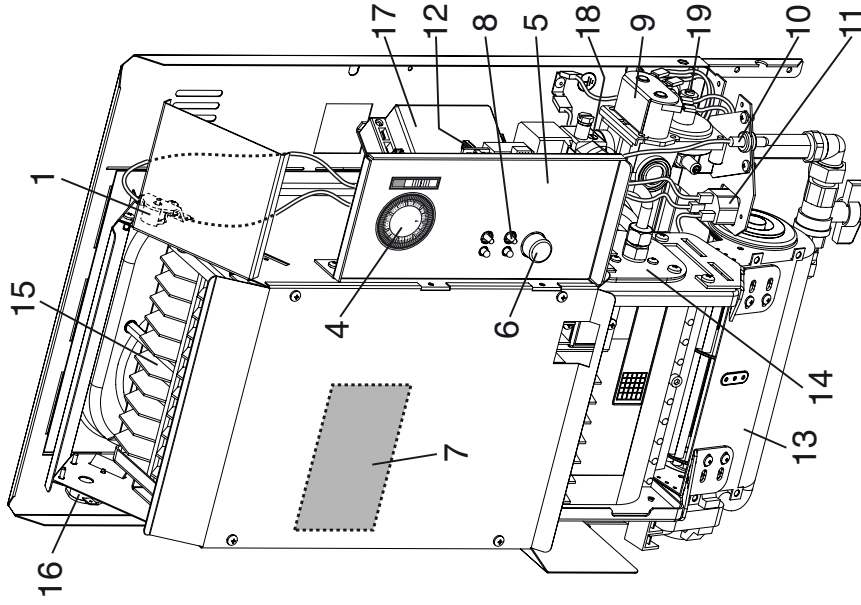

- 1 - safety thermostat
- 2 - MIN pressure adjuster screw
- 3 - ON/OFF knob
- 4 - timer
- 5 - casing
- 6 - room thermostat
- 7 - nameplate
- 8 - fan switch (ON/OFF)
- 9 - gas valve
- 10 - room thermostat sensor
- 11 - power plug
- 12 - power fuse
- 13 - tangential fan
- 14 - burner unit
- 15 - heat exchanger
- 16 - tangential fan thermostat
- 17 - controller
- 18 - MIN adjuster screw
- 19 - MAX adjuster screw

## TECHNICAL DATA

<b>SC-SV</b> Models	<b>18</b>		<b>30</b>		<b>45</b>			
	Methane	LPG	Methane	LPG	Methane	LPG		
Terminal capacity nomination (Qn) Hi	2,10		3,49		5,11		kW	
Terminal capacity reduction (Qn) Hi	0,84		1,42		2,04		kW	
Terminal power convector nomination (Pn)	1,79		3,02		4,35		kW	
Terminal power convector reduction (Pn)	0,71		1,2		1,75		kW	
Terminal capacity fan coil nomination (Qn) Hi	1,88		3,18		4,60		kW	
Terminal capacity fan coil reduction (Qn) Hi	0,74		1,24		1,81		kW	
Right efficiency	90,1		90,2		90,1		%	
Nozzle pressure	12	28,8 /36,8	12	28,7 / 36,7	12	28,6 / 36,5	mbar	
Reduce nozzle pressure	2	6/6,8	2	6/6,8	2	6/6,8	mbar	
Gas consumption (15°C)	0,22		0,36		0,54		m³/h	
		0,16		0,27		0,40	kg/h	
Type of apparatus	C1							
Combustion category	II <sub>2H3+</sub>							
NOx class	3		4		4			
Efficiency class	1							
Nozzle	1							nY
	INJECTOR	0,36	0,19	0,36	0,19	0,36	0,19	mm
	BURNER	1,25	0,73	1,65	0,95	1,98	1,16	mm
Max/min value Atmospheric heated by a convector	78	78	135	135	196	196	m³	
Quantity of air heated	130	130	225	225	335	335	m³/h	
Electrical alimentation	230~50							V~Hz
Power absorbed when in function	100				80		W	
Protection degree	IP20							
Weight with the convector in box	18	18	26,7	26,7	35,9	35,9	kg	
Gross convector weight with fan	19	19	30,7	29	37,9	37,9	kg	

<b>SE</b> MODELS	<b>18</b>		<b>30</b>		<b>45</b>			
	Methane	LPG	Methane	LPG	Methane	LPG		
Terminal capacity nomination (Qn) Hi	2,10		3,49		5,11		kW	
Terminal capacity reduction (Qn) Hi	1,42		2,44		3,58		kW	
Terminal power convector nomination (Pn)	-		-		-		kW	
Terminal power convector reduction (Pn)	1,28		2,18		3,15		kW	
Terminal capacity fan coil nomination (Qn) Hi	1,87		3,18		4,60		kW	
Terminal capacity fan coil reduction (Qn) Hi	-		-		-		kW	
Right efficiency	90,1		90,2		90,1		%	
Nozzle pressure	12	28,8/36,8	12	28,7/36,7	12	28,6/36,5	mbar	
Reduce nozzle pressure	6	14,8/18,8	6	14,8/18,8	6	14,8/18,8	mbar	
Gas consumption (15°C)	0,22		0,37		0,54		m³/h	
		0,16		0,28		0,40	kg/h	
Type of apparatus	C1							
Combustion category	II <sub>2H3+</sub>							
NOx	3		4		4			
Efficiency class	1							
Nozzle	1							nY
		1,25	0,73	1,65	0,95	1,98	1,16	
Max/min value Atmospheric heated by a convector	78	78	135	135	196	196	m³	
Quantity of air heated	130	130	225	225	335	335	m³/h	
Electrical alimentation	230~50							V~Hz
Power absorbed when in function	40		50		70		W	
Protection degree	IP20							

**SV**

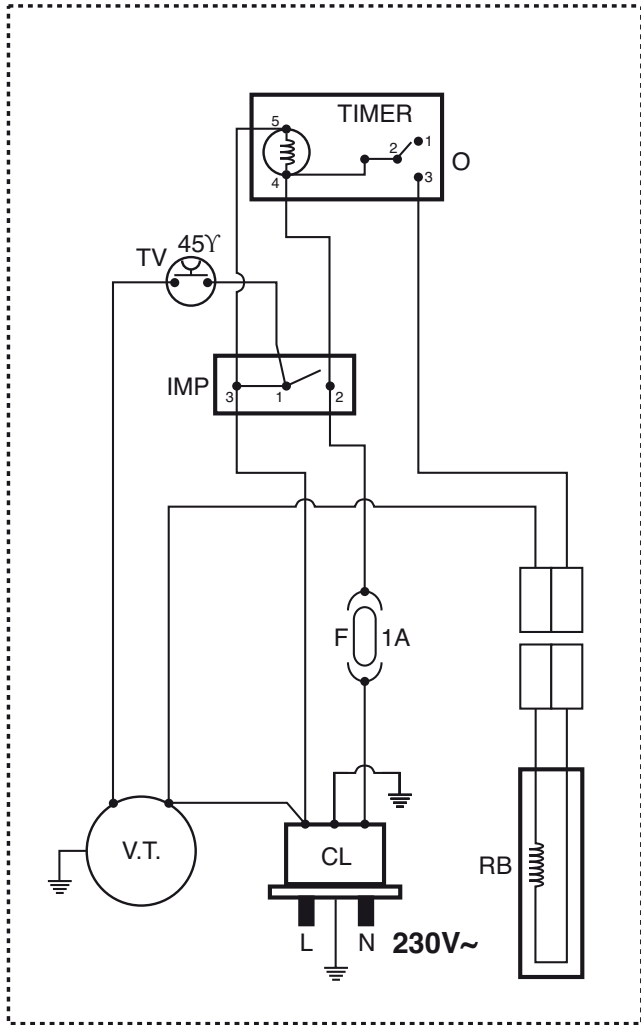
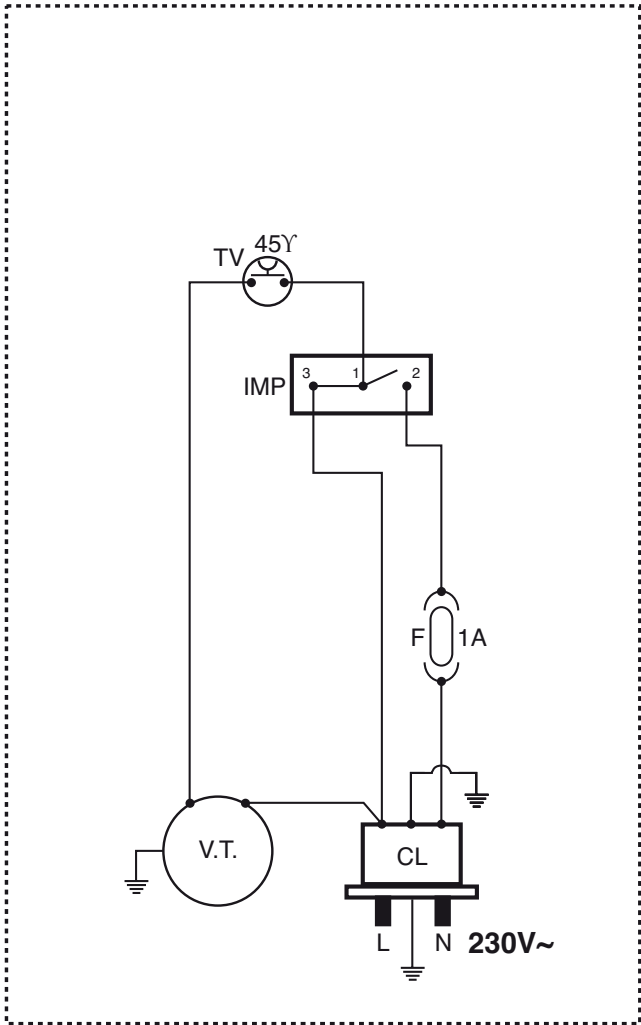

- |     |                    |
|-----|--------------------|
| CL  | LINE CONNECTOR     |
| CVT | CONDENSER          |
| EA  | IGNITION ELECTRODE |
| F   | FUSE               |
| IMP | MANUAL SWITCH      |
| L   | PHASE              |
| N   | NEUTRAL            |
| O   | TIMER              |
| RB  | RESISTANCE         |
| TV  | FAN THERMOSTAT     |
| VT  | TANGENTIAL FAN     |



**SC**

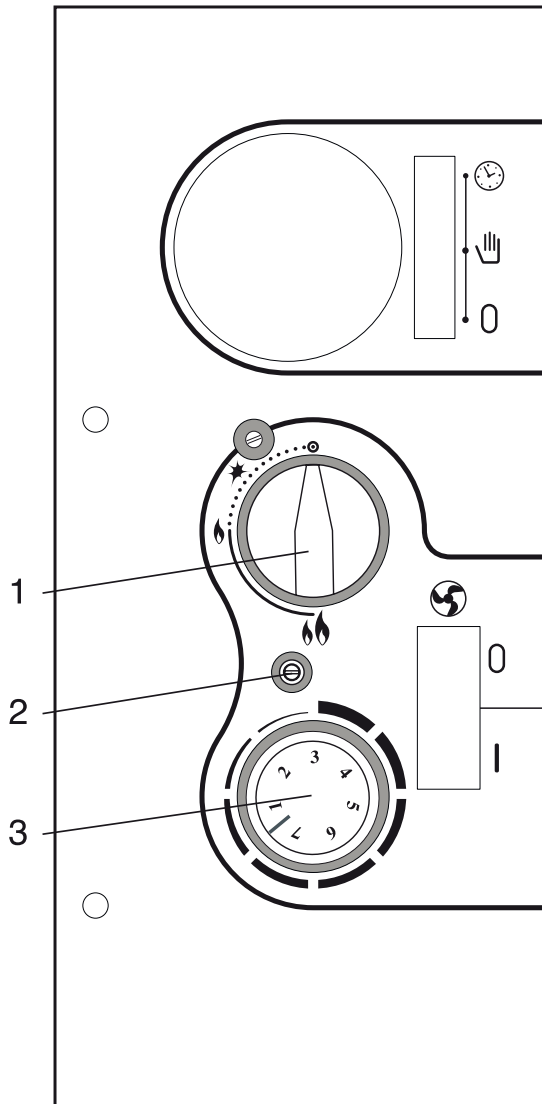

**SV**

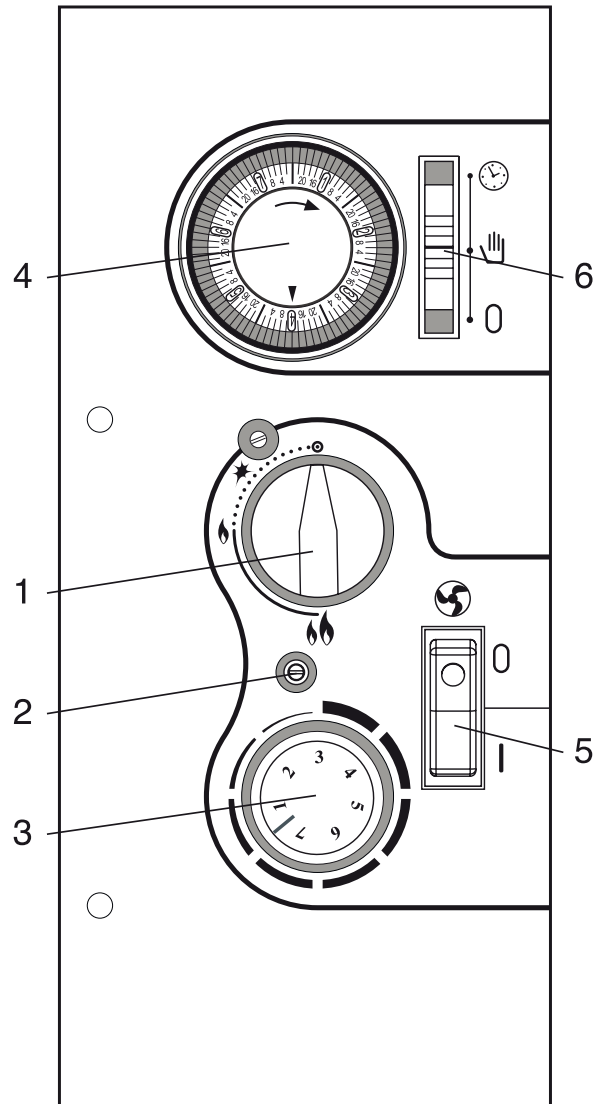

- 1\*** - IGNITION / COMMAND knob
- 2** - PRESSURE REGULATOR SCREW
- 3\*** - Room thermostat
- 4** - Timer
- 5** - TANGENTIAL FAN SWITCH (ON/OFF)
- 6** - Function selector:
  - Timer mode.
  - Heater off.
  - Room thermostat mode.

# SE

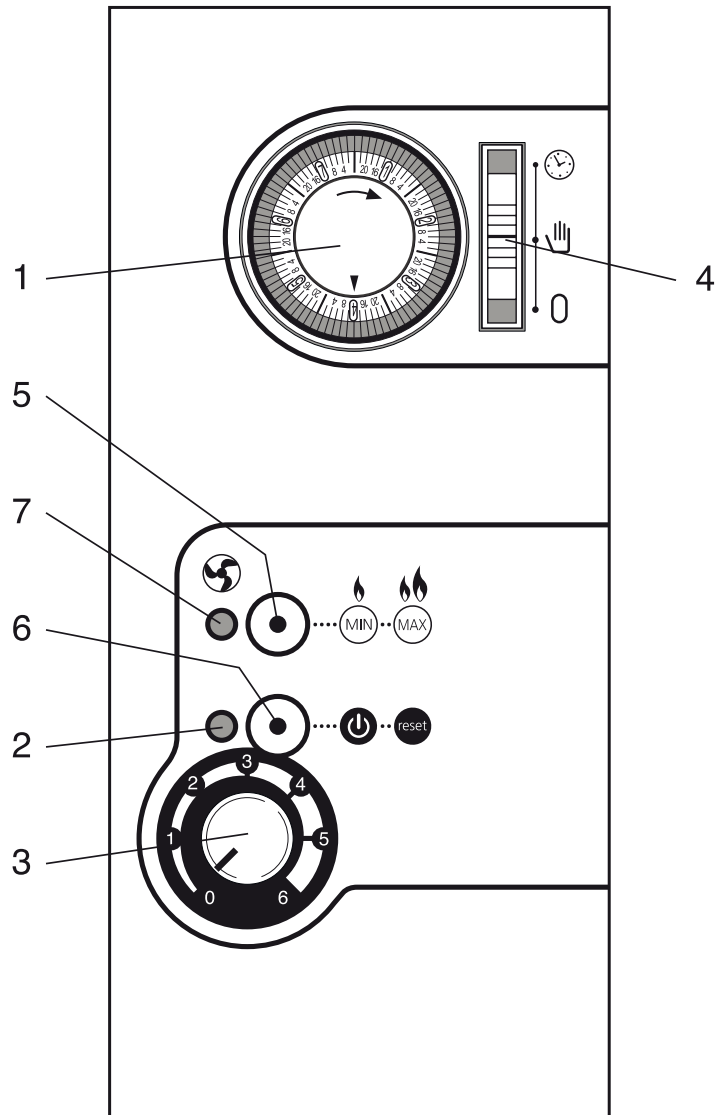

- 1** Timer
- 2** Status indication
- 3** Room thermostat
- 4** Function selector:
  - Timer mode.
  - Heater off.
  - Room thermostat mode.
- 5** Power selector (min/max)
- 6** ON/OFF and release button
- 7** Fan indicator light

## RECEIVING THE PRODUCT

The APPLIANCE is supplied in a cardboard box containing:

- n. 1 Appliance
- n. 1 Steel template
- n. 1 Mounting bracket
- n. 1 Adhesive cutting guide
- n. 4 Dia. 8 mm wall plugs
- n. 4 Dia. 6 mm wall plugs
- n. 1 Terminal
- n. 1 Concentric pipes
- n. 1 Centring spring
- n. 1 O-Ring gasket
- n. 1 Gas cock with unions
- n. 1 Document wallet:
  - n. 1 User instruction booklet
  - n. 1 Installation booklet
  - n. 1 Gas adapter kit
  - n. 1 Spare parts catalogue
  - n. 1 Warranty certificate
  - n. 1 Warranty labels
  - n. 1 Power socket
  - n. 1 Paper template

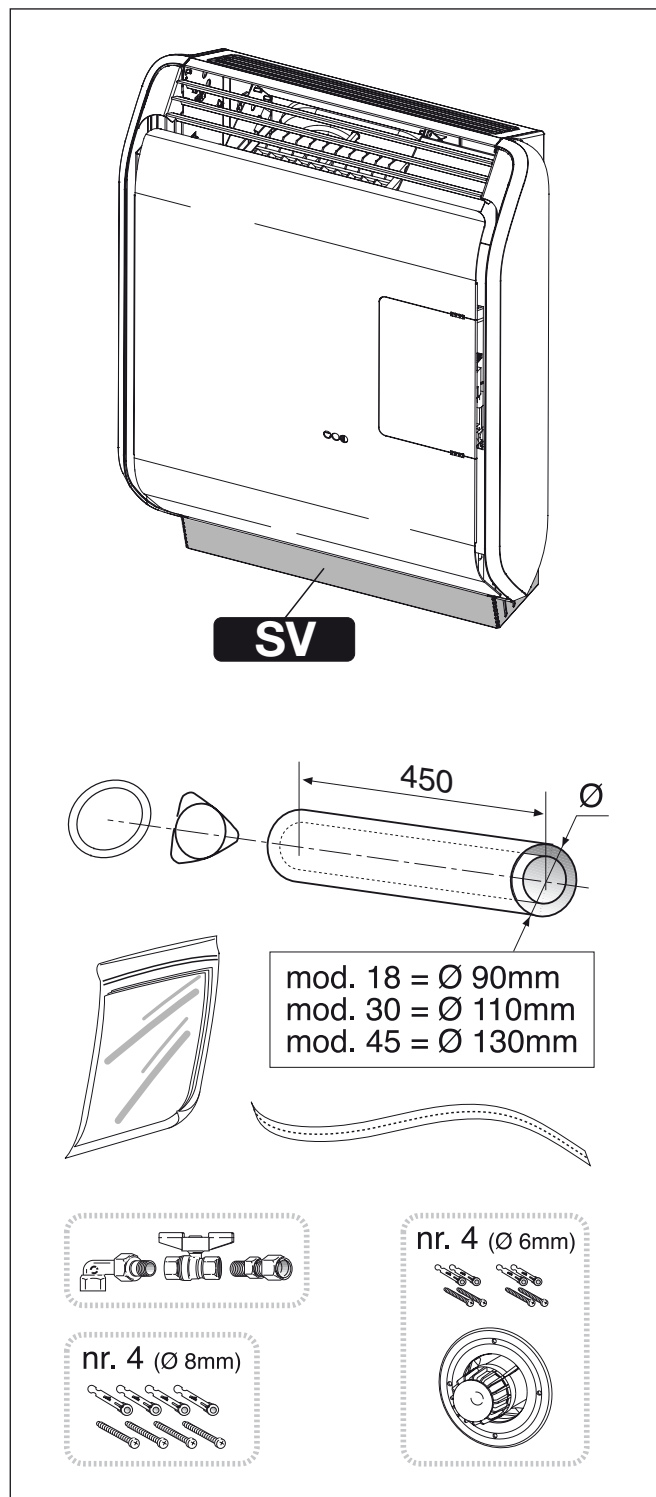

## KIT OF PIPES

To install the convection heater, you will need the PIPE KIT most suited to the type of combustion air intake and fumes discharge, which must be ordered separately from the appliance itself:

<b>MODEL</b>	<b>description</b>
<b>1 8</b>	STD kit. exhaust & intake (0 60/90mm) L = 450 with out side terminal
	STD kit. exhaust & intake (0 60/90mm) L = 900 with out side terminal
	SPECIAL kit. exhaust & intake ( 60/90mm) L=900 <b>Mount from INSIDE</b>
<b>3 0</b>	STD kit. exhaust & intake (0 70/110mm) L = 450 with out side terminal
	STD kit. exhaust & intake (0 70/110mm) L = 900 with out side terminal
	SPECIAL kit. exhaust & intake( 70/110mm) L=900 <b>Mount from INSIDE</b>
<b>4 5</b>	STD kit. exhaust & intake (0 80/130mm) L = 450 with out side terminal
	STD kit. exhaust & intake (0 80/130mm) L = 900 with out side terminal
	SPECIAL kit. exhaust & intake( 80/130mm) L=900 <b>Mount from INSIDE</b>

## DIMENSIONS AND WEIGHTS

		<b>18</b>	<b>30</b>	<b>45</b>	
<b>SC</b>	A	585	585	585	mm
	B	225	225	225	mm
	C	462	642	822	mm
	Kg	16,5	25	34	
<b>SV</b>	A	630	630	630	mm
	B	225	225	225	mm
	C	462	642	822	mm
	Kg	17,5	26,5	36	
<b>SE</b>	A	630	630	630	mm
	B	225	225	225	mm
	C	462	642	822	mm
	Kg	17,5	26,5	36	

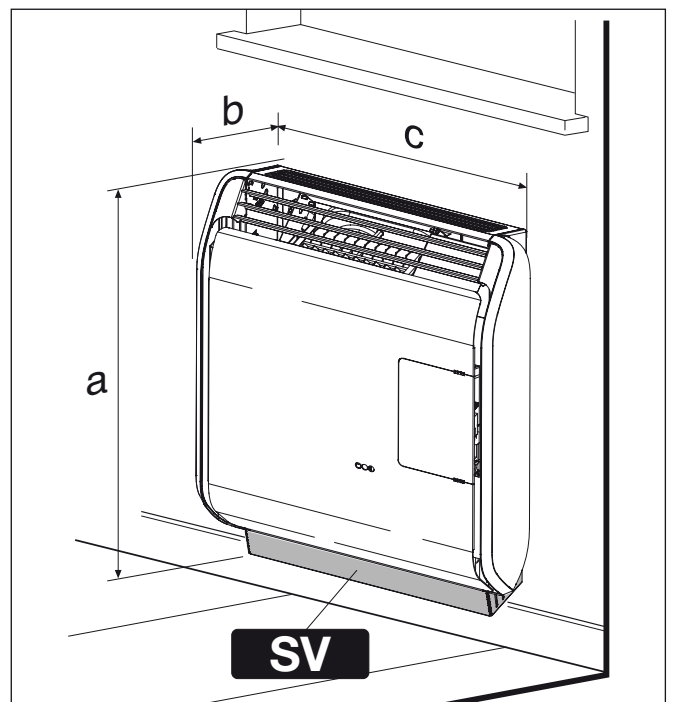

## GENERAL INFORMATION

The appliance is sealed off from the room; its combustion air is drawn from outside.

- DO NOT use non-original accessories or parts for the installation; doing so is hazardous.
  - DO NOT route the power cable over hot surfaces such as the air outlet grilles or flue pipes.
- once the appliance has been installed, the installer must inform the user on how to use it:
- DO NOT place curtains, towels or other such objects on the appliance; doing so can cause it to malfunction and compromise the circulation of air in the room.
  - DO NOT obstruct the appliance's intake/discharge terminal with laundry or carpets.



## POSITIONING THE APPLIANCE

Before you install the appliance, make sure there is sufficient clearance for it to operate properly and for maintenance.

Make sure that the wall to which you are going to mount it is able to support its weight; check that the included plugs can bear the appliance's weight in relation to the material of the wall; if not, use more appropriate equipment.

Check for wooden, plastic and other non-heat resistant mouldings which may come into contact with the flue pipes.

The material of the wall must be able to handle the heat of the flue pipes (around 180°C)

 If the wall is not sufficiently heat resistant, you must provide an air gap around the flue pipe and insulate it with heat resistant material, or make a hole at least 4 cm larger than the flue pipe.

 Do not install the heater inside the clearances for bathrooms or showers, or close to water delivery equipment. Such installations require special protective equipment to make the appliance conforming with the applicable electrical safety regulations.

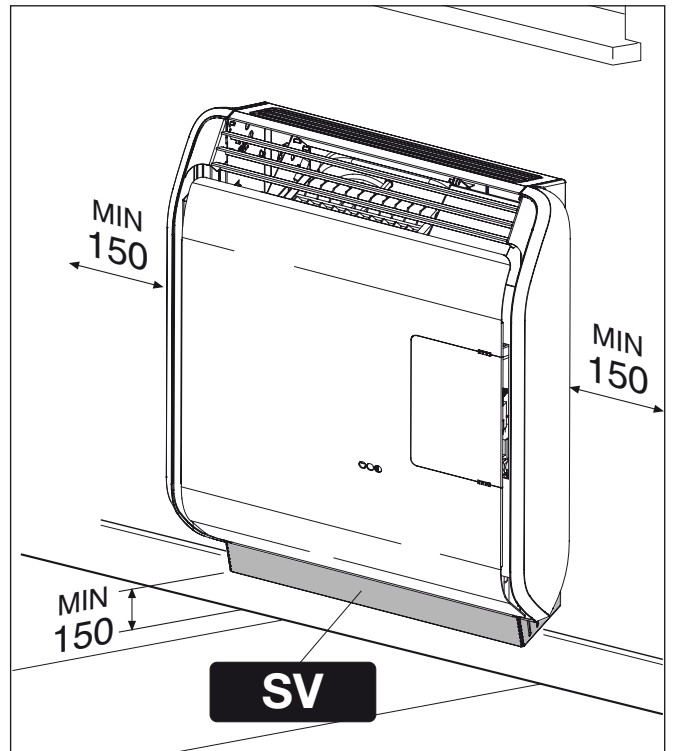

## INSTALLATION PROCEDURE

the installation procedure breaks down into the following steps:

- positioning the appliance
- cutting the intake/discharge pipes to length
- installing the flue and air intake pipes, chosen among:
  - Concentric pipe kit L = 500mm (included)
  - Concentric pipe kit L = 900mm
  - Concentric pipe SPECIAL kit L = 900mm
- installing the combined intake/exhaust pipe terminal
- installing the gasket
- installing the heater itself
- electrical hookup
- gas line hookup

## TYPE OF INSTALLATION PER UNI CIG 7129

We show below the types of pipe (intake and discharge) installation, pursuant to UNI CIG 7129, for products with the following structural and installation specifications.

### WALL MOUNTING (concentric pipes, combined terminal)

Important! Convection heaters are intended for installation against the wall only (the intake and flue pipes run through the wall).

Before starting the installation, make sure the diameters, total lengths and the terminals of the pipes are match those indicated on the Overall Measurements table.

### INSTALLING THE TEMPLATE AND BRACKET

- Place the paper template (included with the pipes kit) onto the wall and check the clearances around the appliance.
- Mark the hole "a" on the paper template (3).
- Make a small initial hole, then use a suitable cutter to make the big hole for the pipes.
- Cut the pipes to length and fit them into the hole.
- Fit the protruding lip of the template (1) onto the pipes.
- Mark the hole "b" on the metal template and drill it, then secure the template and bracket (2) to the wall.
- Level the horizontal bracket and mark the two external holes "c".
- Make the two holes "c" and secure the horizontal bracket.
- Mark and drill the hole "d" and secure the template.

 **Drill the hole as shown in the table.**

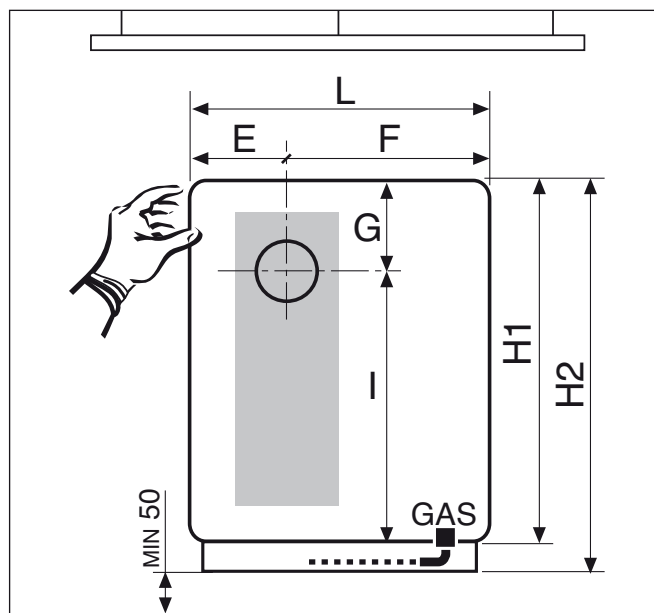
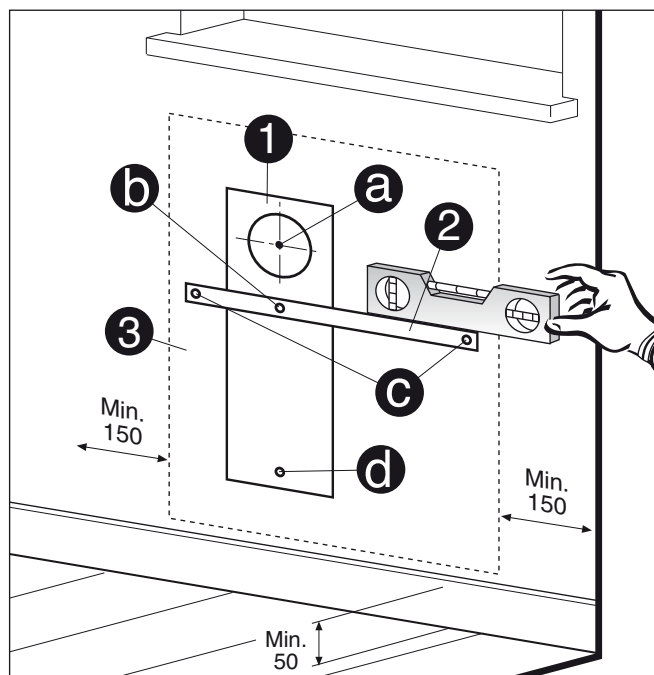
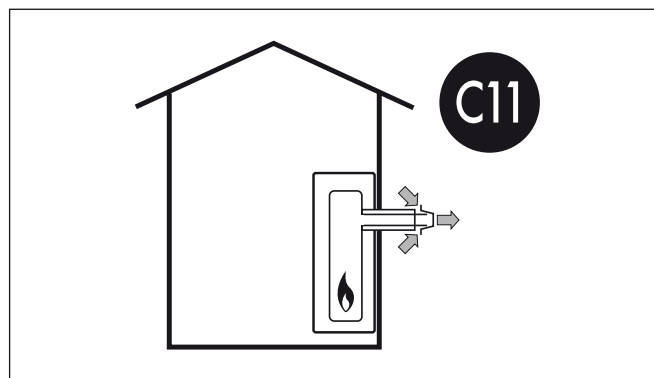

		18	30	45	
<b>SC SV SE</b>	<b>E</b>	180	282	360	mm
	<b>F</b>	282	360	462	mm
	<b>G</b>	146	146	146	mm
	<b>L</b>	462	642	822	mm
<b>SC</b>	<b>H1</b>	585	585	585	mm
	<b>I1</b>	439	439	439	mm
<b>SV SE</b>	<b>H2</b>	630	630	630	mm
	<b>I2</b>	486	486	486	mm

## INTAKE/FLUE PIPE ASSEMBLY AND GAS CONNECTION

- Cut the pipes to length to suit the thickness of the wall, as shown in the figure.

**IMPORTANT:** the outer steel pipe must be cut to the same length as the thickness of the wall.

**IMPORTANT:** cut the inner pipe (flue) so that, when it is installed, it is aligned outwardly with the external pipe and protrudes by 10 mm from the interior wall. Cut the pipe using the adhesive cutting tape as a guide stuck to the pipe at the position of the cut itself.

**IMPORTANT:** Cutting must be perpendicular to the pipe axis, please handle with care in order not to deform the pipes.

Insert the outer pipe through the hole, then fit the inner pipe into the outer one.

- Insert the flue/intake terminal onto the concentric pipes; mark the centres of the four holes for the 6 mm wall mounting plugs.

- Remove the terminal, drill the four 6 mm holes, and fit the plugs into them.

- Fit the terminal onto the concentric tube and secure it tightly to the wall with the wall screws.

**IMPORTANT:** if the outside pipe protrudes from the wall (terminal not snug against wall), the burners may malfunction and even go out or shut off the pilot light, especially in bad weather (strong wind, rain, etc.).

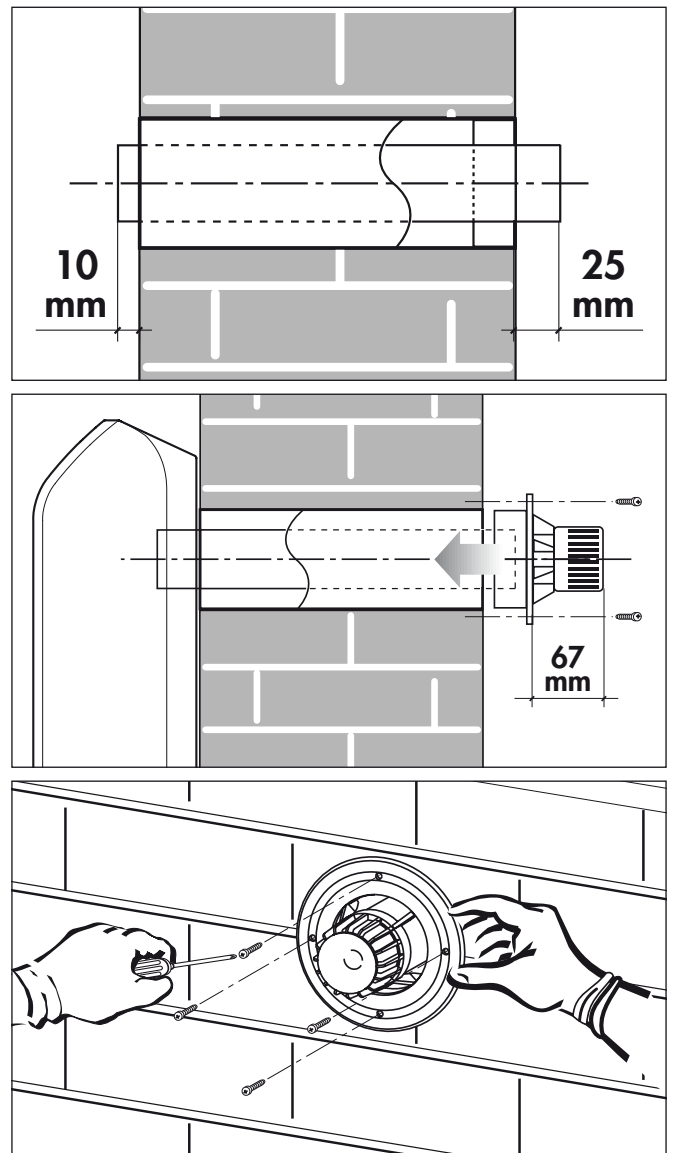

## Installing the SPECIAL PIPES KIT from inside the room

First make the hole in the wall, the cut the SPECIAL KIT pipes to length (thickness of the wall), removing the excess length as shown in the figure.

**IMPORTANT:** The external pipe (fixed to the aluminium outlet) must be cut to match the exact thickness of the wall.

**IMPORTANT:** cut the inner pipe (flue) so that, when it is installed, it is aligned outwardly with the external pipe and protrudes by 10 mm from the interior wall. Cut the pipe using the adhesive cutting tape as a guide stuck to the pipe at the position of the cut itself.

**IMPORTANT:** Cutting must be perpendicular to the pipe axis, please handle with care in order not to deform the pipes.

Before inserting the pipes into the hole in the wall, fix the special kit to the flanging on the mounting template. Use the included screws.

**IMPORTANT:** The Special Kit is different from the Standard one: the centring spring is missing. You don't need it because the pipes are fixed coaxially to the aluminium outlet.

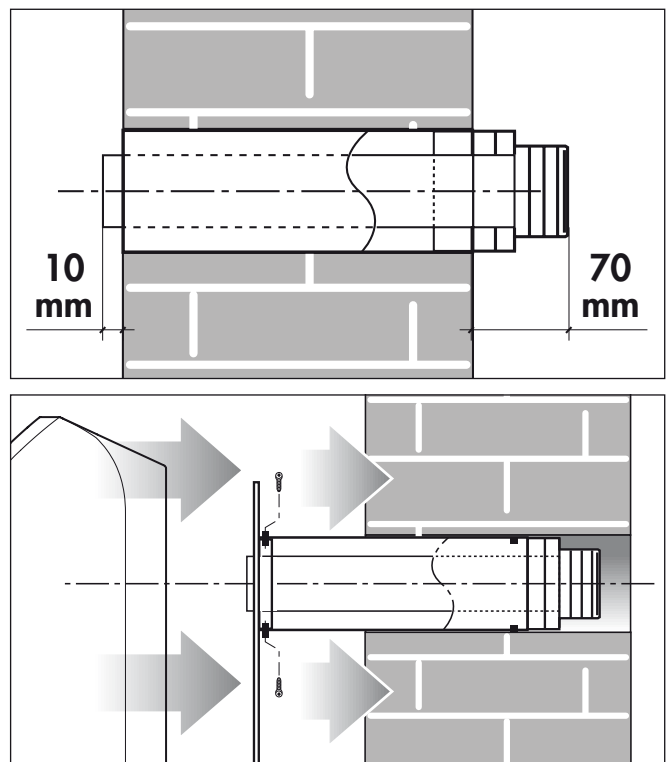

## ASSEMBLING THE CONVECTION HEATER

- Make sure you have completed the previous steps correctly: You can now install the heater to the wall. Remove the jacket from its packing. Now extract the body of the heater.

- Fit the O-Ring gasket to the intake fitting.

- Now fit the lower section of the gasket to the bottom of the metal template mounted to the wall. Fit it snugly so that the discharge stub of the heat exchanger fits onto the inner pipe in the wall. Tighten the back plate down with the 2 5MA screws on the bracket (the gasket, mounted onto the outer tube, must be completely compressed between the lower chamber of the heater and the metal template; if it is not, the circuit is no longer air tight, which is hazardous and can cause malfunctions).

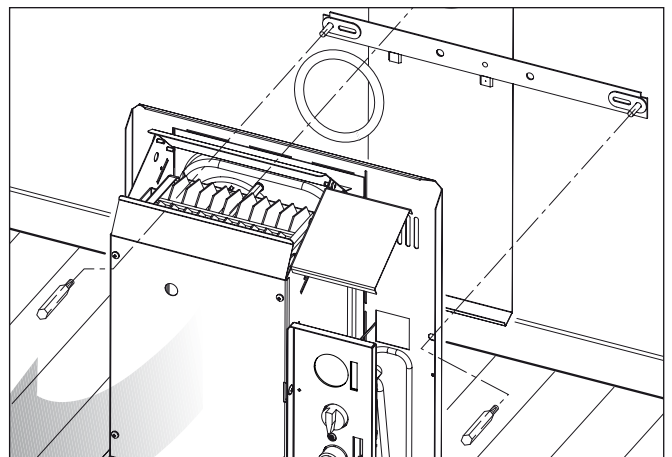
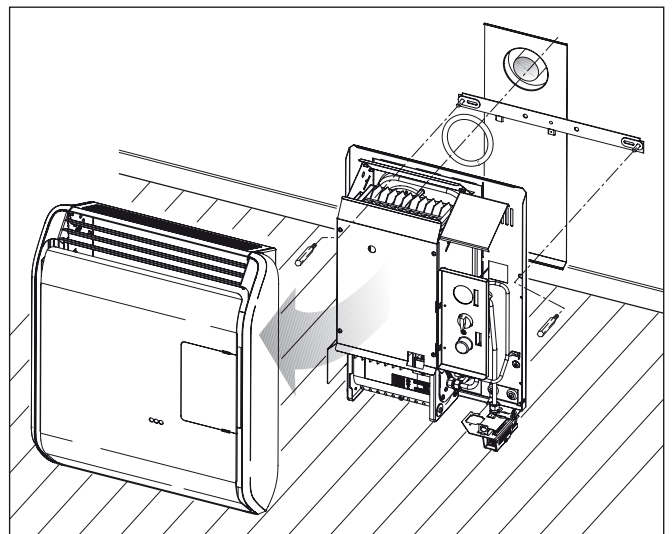

## ELECTRICAL HOOKUP

The equipment is supplied completely cabled and with a mains plug.

You need only make up a HAR H05 RRF power cable with at least 1 mm<sup>2</sup> cross section wires, assembled to the loose plug at one end and to the plug or master switch at the other.

⚠ A proper earth connection is obligatory. The manufacturer is not liable for any damage caused by unearthed equipment. For all electrical work, refer to the wiring diagram included in this booklet

⚠ Provide a mains disconnection device upline of the power cable (omni-polar disconnect or plug), with a contact air gap of at least 3 mm.

The polarities must be observed: blue is NEUTRAL and yellow/green is EARTH.

⚠ Strip the earth wire at least 2 cm longer than the other two wires.

⊘ Do not use the gas or water pipes to earth the appliance.

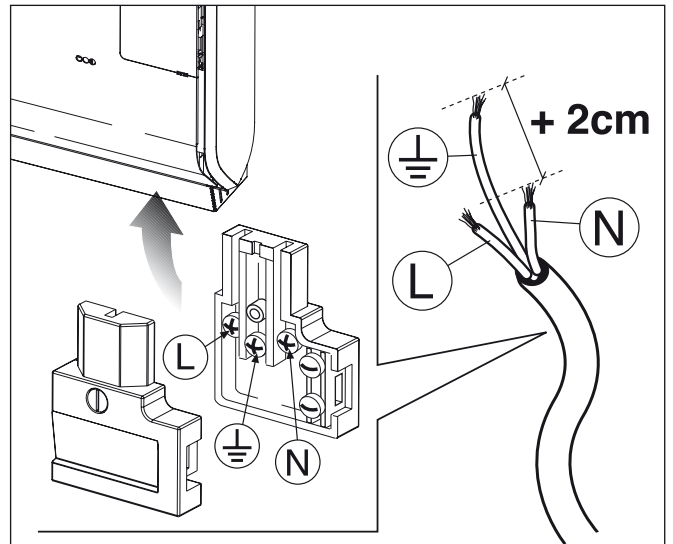

## GAS HOOKUP

Ensure that the heater is configured for your gas supply; this information is given on the nameplate mounted to the heat exchanger jacket.

Connect the heater to the gas supply line with the union and cock included with the appliance, using a rigid pipe and regulatory fittings.

The fitting on the appliance itself is a 3/8" M union per UNI ISO 7/1.

If the gas supply is on the right side of the heater, use a nipple to resolve any clearance issues.

Once you have completed the gas line hookup, run the tightness tests specified in the applicable installation regulations.

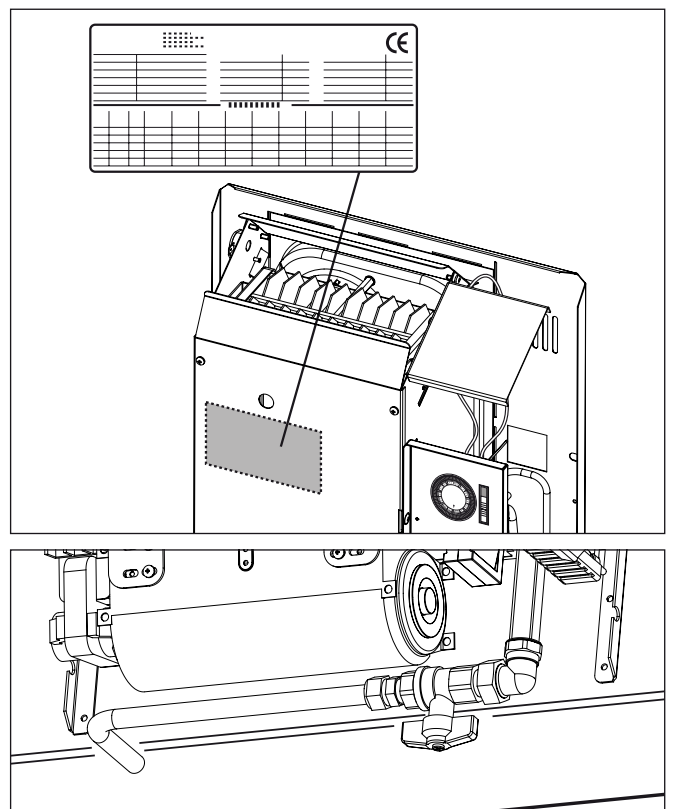

## PRELIMINARY OPERATIONS

The convection heater is supplied configured for methane gas (G20), and is pre-adjusted at the factory. Note: the apparatus can also be requested in the LPG version.

Before commissioning the heater, check that:

- that the appliance is of the correct gas type;
- that the gas hookup has been completed properly and the gas cock is open;
- that the electrical hookup has been completed correctly.

The neutral/phase polarity and the earth connection must also be correct (for models with fan / timer).

During commissioning, you may note unpleasant odours and vapours - these are not hazardous. We recommend ventilating the room thoroughly.

## COMMISSIONING

### TURN THE APPLIANCE ON:

- Check that the gas cock is open;
- fit the loose plug into the socket on the appliance (fan/timer models);
- Set the master switch, if present, to ON, or fit the power plug into the wall socket (fan/timer models);
- Set the fan mode with the fan On/Off switch (fan models);
- Set the timer mode switch to Manual (timer models);

### SC/SV model (piezoelectric ignition)

- Turn the thermostat knob to 7 (maximum setting).
- Press in and turn the ignition knob from "OFF I" to "spark" and then "flame"; you will hear a click (piezoelectric ignition).
- Keep holding the ignition knob down for a few seconds to allow the flame to stabilise, then release it and check that the pilot is still on (just as for kitchen hobs).
- With the pilot still burning, turn the ignition knob leftwards to the "small flame + large flame" position.
- The appliance will now run at temperature setting 7 (max); turn the thermostat knob to the desired setting, from 1 (13°C, min) to 7 (35°C, max).

### SE model (electronic ignition)

- Press the On/Off button on the control panel (green light on).

If a malfunction occurs, the appliance will automatically go into SHUTDOWN mode (red light on); to restore normal operation, press the RELEASE button (above the On/Off button).

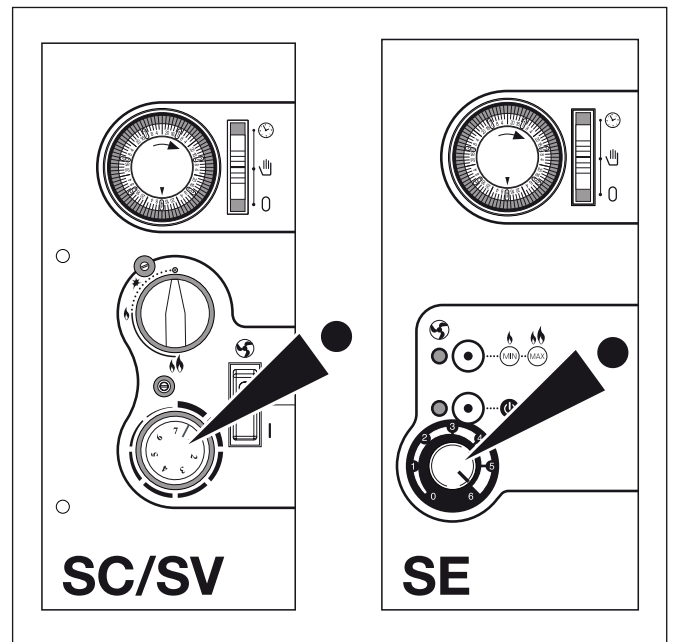

## MALFUNCTION

If you experience problems with ignition or operation, or the pilot light goes out, the heater will go into SHUTDOWN mode, and will automatically shut off the gas supply.

### SC/SV model (piezoelectric ignition)

Wait for 1 minute for the thermocouple interlock to cool down before repeating the ignition procedure.

**!** This operation can be repeated only 2 or 3 times. If the heater doesn't start after three attempts, set the master switch to OFF and contact Technical Service.

- Once the heater is running, set the clock and timer (if present) for automatic operation, by setting the function selector to timer mode (refer to the user instruction booklet for details)

### SE model (electronic ignition)

- press the On/Off/Reset button to reset the appliance.

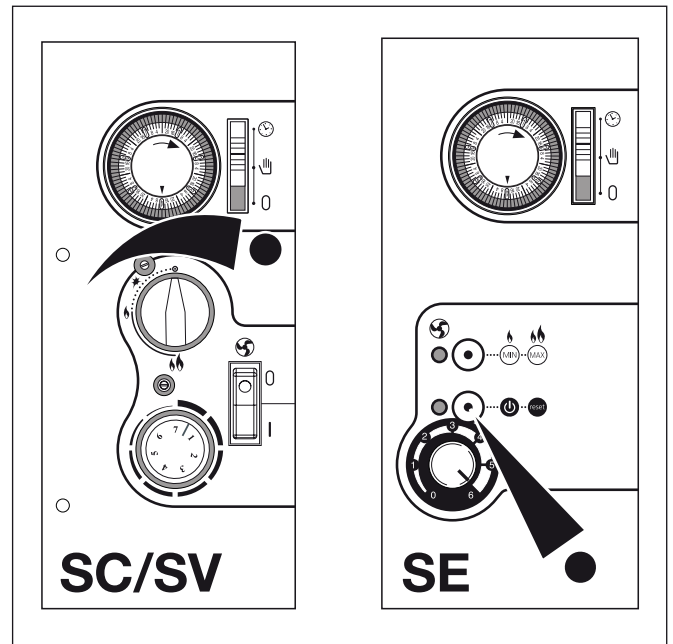

## CONTROLS

Once the heater is on, check that:

- the gas pressure at the gas intake is:
- the appliance can be shut off and back on again:
  - with the master switch on the control panel
  - with the room thermostat or timer
- the appliance can be shut off and back on again:
  - The fan starts running when the thermostat trips.

		18	30	45	
<b>SC SV</b>	<b>G20</b> nom./rid.	12,0/2,0	28,8/6,0	36,8/6,8	mbar
	<b>G30</b> nom./rid.	12,0/2,0	28,7/6,0	36,7/6,8	mbar
	<b>G31</b> nom./rid.	12,0/2,0	28,6/6,0	36,5/6,8	mbar
<b>SE</b>	<b>G20</b> nom./rid.	12,0/6,0	28,8/14,8	36,8/18,8	mbar
	<b>G30</b> nom./rid.	12,0/6,0	28,7/14,8	36,7/18,8	mbar
	<b>G31</b> nom./rid.	12,0/6,0	28,6/14,8	36,5/18,8	mbar

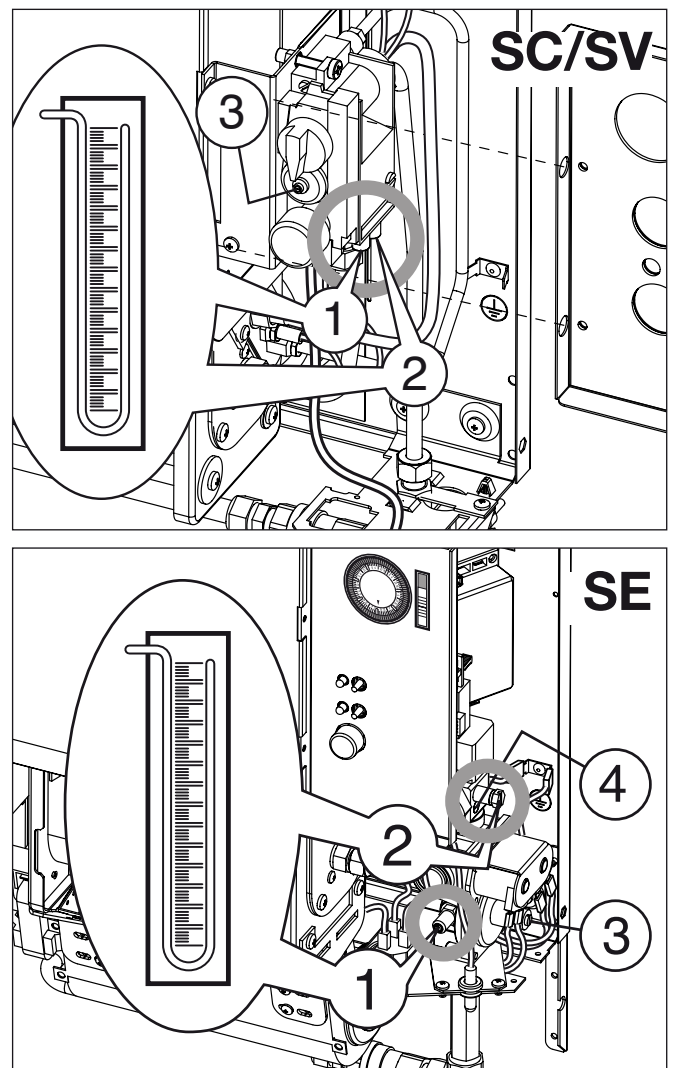

## CHANGING THE GAS TYPE

The convection heater is supplied configured for methane gas (G20), as indicated on its nameplate. It can be adapted to LPG (G30/G31) with the injector kit included in the package.

This must be done by Technical Service or by a person authorised by the manufacture, even after the heater has been installed.

### SC/SV model (piezoelectric ignition), procedure:

- Disconnect the electrical power supply.
- Remove the jacket.
- Shut off the gas supply and disconnect the pipes.

#### Pilot burner injector replacement

- Unscrew the M10x1 collar from the pilot burner fitting, extract the gas pipe with the injector still attached to it.
- Replace the injector with the one for the new gas type.

**Important! Make sure that the groove in the injector's head fits onto the key on the gas outlet.**

- In reverse order, restore the pipe with the injector attached to it, taking care not to dislodge or crush it when you tighten down the collar, which must be hand tightened before you finally tighten it down with a wrench.

The injector mounts tightly, so there is no need for a gasket.

#### Main gas burner injector replacement

- Unscrew the collar (4, 3/8" F) from the MAIN BURNER injector mount fitting;
- unscrew the injector mount fitting from the injector itself;
- Unscrew the injector (5) and replace it with the new one. Thread it on by hand and only then tighten it down with a wrench.

The injector and injector mount fitting install tightly to each other, there is no need for a gasket;

- Check that the value stamped on the injectors match those in the table.

- restore the burner unit in reverse order.
- Make the adjustments indicated in Chapter ADJUSTMENTS; also check that the gas fittings on the pipe running from the gas cock to the burner unit are tight.

- Change the gas label (see IDENTIFICATION) and seal the adjustment equipment once it is calibrated, with a drop of paint or silicone.

Never leave the old gas label on the appliance; this can lead to misunderstanding and is hence very hazardous.

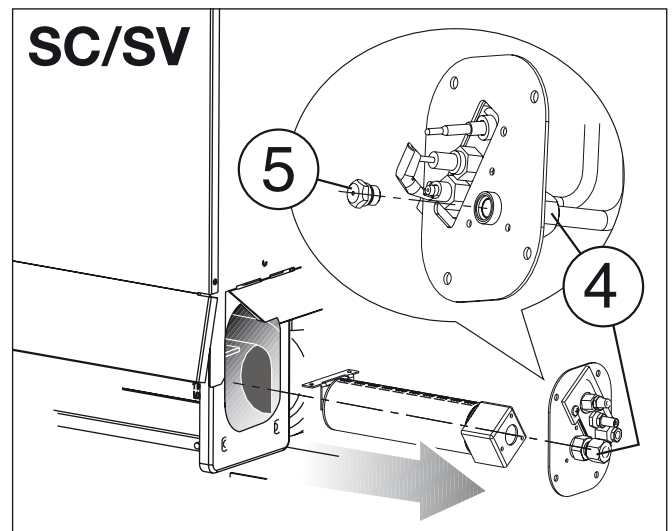
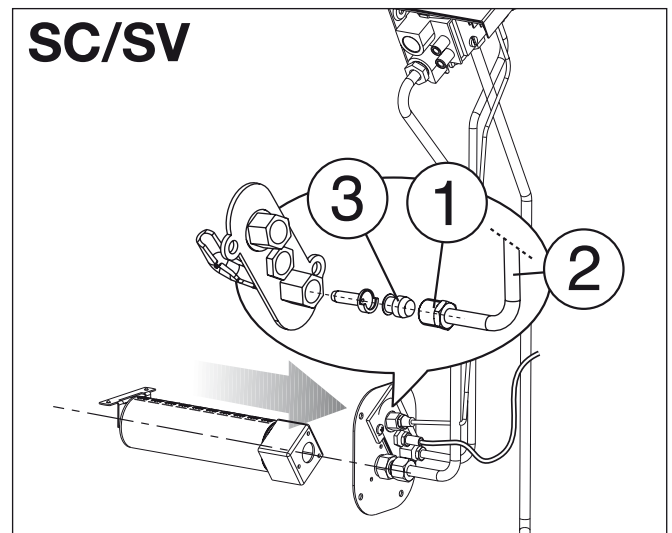

Model	mm	methane	LPG
<b>18</b>	Ø	1,25	0,73
<b>30</b>	Ø	1,65	0,95
<b>45</b>	Ø	1,98	1,16

### SE model (electronic ignition), procedure:

- Disconnect the electrical power supply.
- Remove the jacket.
- Shut off the gas supply and disconnect the pipes.
- Disconnect the gas pipe collar from the injector mount fitting;
- Undo the injector mount fitting (4) with the burner injector (5);
- Undo the injector (4) and replace it with a new one, making sure to thread it fully on by hand and then tighten it down with a wrench.

The injector and injector mount fitting mount tightly to each other, there is no need for a gasket;

- Check that the value impressed on the injector matches that given in the table.
- Restore the burner unit in reverse order.
- Make the adjustments indicated in Chapter ADJUSTMENTS; also check that the gas fittings on the pipe running from the gas cock to the burner unit are tight.
- Change the gas label (see IDENTIFICATION) and seal the adjustment equipment once it is calibrated, with a drop of paint or silicone.

Never leave the old gas label on the appliance; this can lead to misunderstanding and is hence very hazardous.

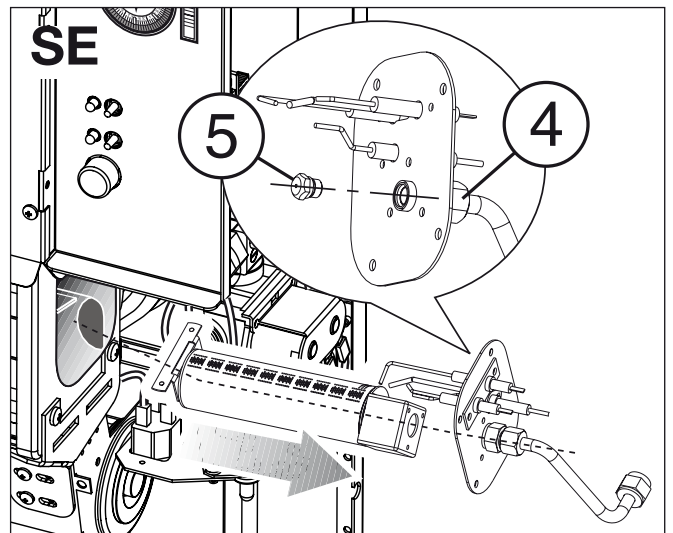
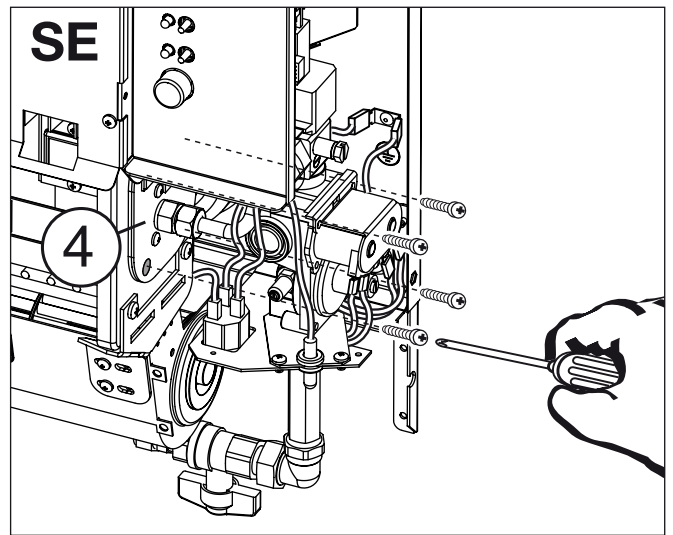

Model	mm	methane	LPG
<b>18</b>	Ø	1,25	0,73
<b>30</b>	Ø	1,65	0,95
<b>45</b>	Ø	1,98	1,16

## ADJUSTMENTS

The heater is supplied configured for methane gas operation (G20) as indicated on the nameplate, and is factory adjusted.

To change the settings, for example, after extraordinary maintenance, after having replaced the gas valve, or after having changed the gas type from methane to LPG or back, proceed as follows.

The adjustments may only be made by the manufacturer's Technical Service.

*NOTE: The appliance may be ordered from the manufacturer in the LPG version.*

Open the gas cock and start the heater at maximum power (thermostat set to pos. 7).

### Methane G20 (20mbar); nominal and minimum pressure adjustment.

#### Checking the supply pressure

- slacken off the pressure port screw (1), connect the pressure gauge and check that the mains pressure (1) is between 17 and 25 mbar (as shown in the table), then remove the pressure gauge and close the port.
- slacken off the pressure port screw (2), connect the pressure gauge and check that the nominal and minimum pressures (2) match the values given in the table.

#### Nominal pressure adjustment

With the appliance running at maximum power, and the thermostat knob turned to pos. 7.

- check that the nominal pressure values match those given in the table.

If necessary, adjust with the pressure regulator on the gas valve (the screw has a slot which is accessible through the hole between the thermostat knob and the ignition/control knob).

Turn the regulator screw **CLOCKWISE** to increase the pressure and **COUNTERCLOCKWISE** to decrease it.

#### Minimum pressure adjustment

**Always set the minimum pressure only after having first set the maximum pressure!**

With the appliance running at minimum power, and the thermostat knob turned to pos. 1.

- check that the minimum pressure values match those given in the table.

If necessary, adjust them with the minimum flow rate regulator screw on the right side of the gas valve.

Turn the regulator **CLOCKWISE** to decrease the pressure and **COUNTERCLOCKWISE** to increase it.

Once the settings have been made, seal both the pressure and minimum flow rate regulators with a drop of paint, then disconnect the pressure gauge from the pressure port and turn in the screw.

### - LPG - butane G30 (29 mbar) and propane G31 (37 mbar); nominal and minimum pressure adjustment.

#### Checking the supply pressure

- slacken off the pressure port screw (1), connect the pressure gauge and check that the supply pressure is 29 mbar for butane and 37 mbar for propane, then remove the gauge and close the port.

If the mains pressure is too low, use the low pressure regulator on the main manifold or the regulator on the gas canister itself.

Check that the vaporisation capacity of the LPG system is adequate.

#### Nominal pressure adjustment

With the appliance running at maximum power, slacken off the pressure port screw (2), connect the pressure gauge and check that the nominal pressure values match those given in the table (Injector pressure).

In LPG operation, for category 3+ only, the regulator must be decommissioned by turning the regulator screw clockwise (3 for model SC/SV and 1 for model SE) to a value just below the maximum supply pressure. Disconnect the pressure gauge and close the port.

If the appliance is set to pure propane, to prevent the heat exchanger overheating, you must check that the unit is specified for this type of gas only and not for a propane/butane mix or pure butane.

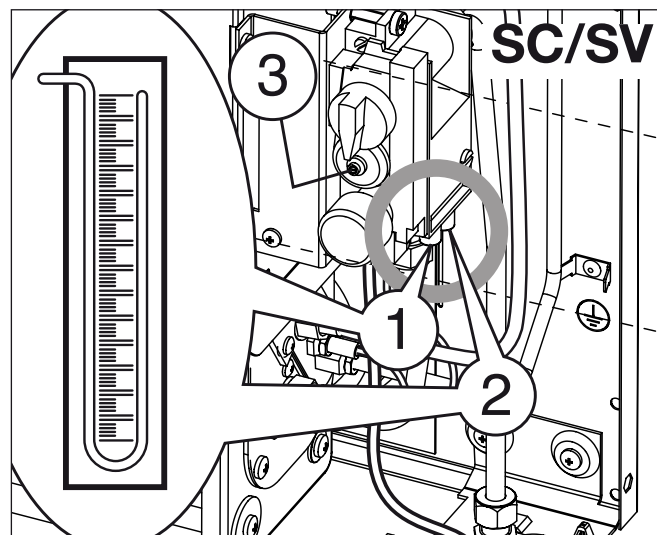

MODEL	BUTANE Rat. / Low.	PROPANE Rat. / Low.	
<b>18</b>	28,8 / 6,0	36,8 / 6,8	mbar
<b>30</b>	28,7 / 6,0	36,7 / 6,8	mbar
<b>45</b>	28,6 / 6,0	36,5 / 6,8	mbar

### Minimum pressure adjustment

**Always set the minimum pressure only after having first set the maximum pressure!**

With the appliance running at minimum power, and the thermostat knob turned to pos. 1.

- Check that the minimum pressure values match those given in the table.
- Use the minimum flow rate regulator screw on the right side of the gas valve.

Turn the regulator **CLOCKWISE** to decrease the pressure and **COUNTERCLOCKWISE** to increase it.

Once the settings have been made, seal both the pressure and minimum flow rate regulators with a drop of paint, then disconnect the pressure gauge from the pressure port and turn in the screw.

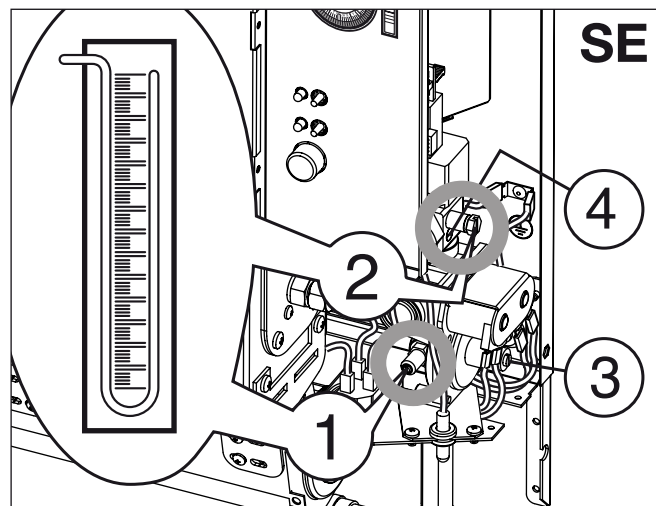

MODEL	BUTANE nom. / red.	PROPANE nom. / red.	
<b>18</b>	28,8 / 14,8	36,8 / 18,8	mbar
<b>30</b>	28,7 / 14,8	36,7 / 18,8	mbar
<b>45</b>	28,6 / 14,8	36,5 / 18,8	mbar

## ROUTINE MAINTENANCE

Routine maintenance must be run once a year to ensure that the appliance runs safely and efficiently throughout its service life. Doing so also reduces consumption and polluting emissions.

Note that the appliance must be serviced by the manufacturer's Technical Service or a qualified technician who will clean the burner and the ignition and flame detector electrodes and check the appliance's settings, according to need.

### Preliminary operations:

- Disconnect the electrical power supply by pulling the power socket from the plug on the appliance itself or setting the master switch to OFF;
- close the gas cock.
- wait for the convection heater to cool down completely;

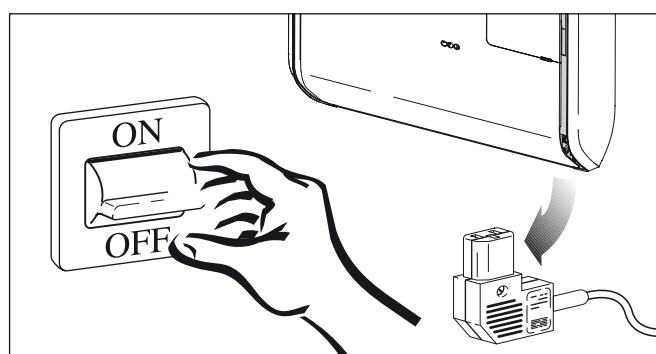
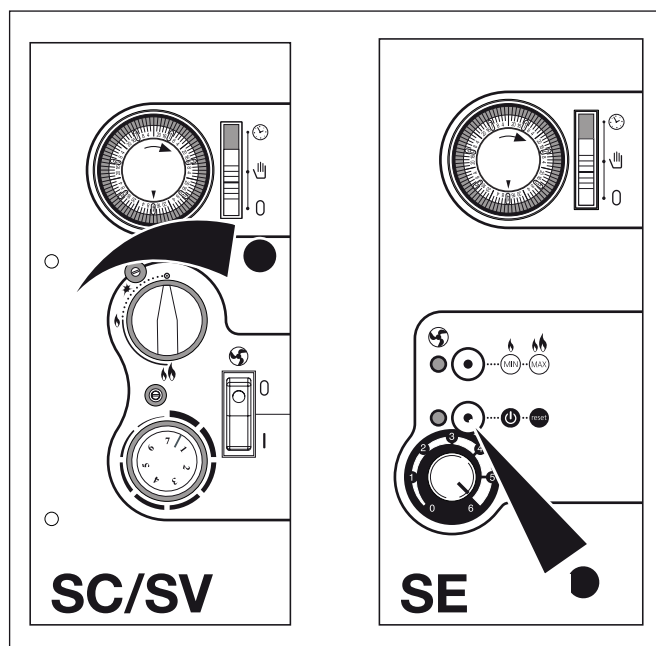

## CLEANING THE CONVECTION HEATER

### *Cleaning the outside of the heater*

Clean all accessible parts to remove any dust, cobwebs and similar dirt.

Use compressed air to blow off any dust in hard to reach areas.

Do not use solvents or abrasive detergents to clean the plastic or painted surfaces; doing so can damage them. Use commercial neutral detergents.

Do not grease synthetic parts.

To clean the jacket, use a soft cloth and neutral household cleaning products (car shampoo, etc.).

**! Do not pour fluids onto the jacket or other areas of the appliance, doing so can seriously damage it.**

### *Cleaning the inside of the heater*

To remove and restore the jacket, refer to REMOVING AND RESTORING THE JACKET.

### *Cleaning the burner*

Use compressed air to thoroughly clean the burner, especially if the heater is operating in a dusty environment or has been out of use for a long time; first blow through the injector mount gas fitting, and then through the threaded hole after removing it; this blows out any residue and dirt resulting from combustion. Now check the condition of the burner itself.

Make sure the injector is in good condition; if it is not, blow compressed air through it to remove any dirt.

**! DO NOT use metal tools for cleaning!**

### *Cleaning the electrodes, SC/SV models (piezoelectric ignition)*

The ignition electrode must be cleaned with care; after a long period of use, the electrode wire and the ceramic insulation become more fragile due to heating.

Remove and restore the ignition electrode as follows:

- disconnect the high voltage cable (5) from the electrode connector;
- undo the collar (6) and extract the electrode (7);
- fit a new electrode in reverse order; it will only fit in one position;

### *Cleaning the electrodes, SE model (electronic ignition)*

The ignition (1) and detector (2) electrodes must be cleaned with care; after a long period of use, the electrode wire and the ceramic insulation become more fragile due to heating. Remove them as follows:

- undo the screws and extract the electrode unit, which must be cleaned with a metal brush;
- restore the electrode unit and replace the gasket (3) if necessary; take care not to damage the ceramic insulation; the unit will install in one position only.

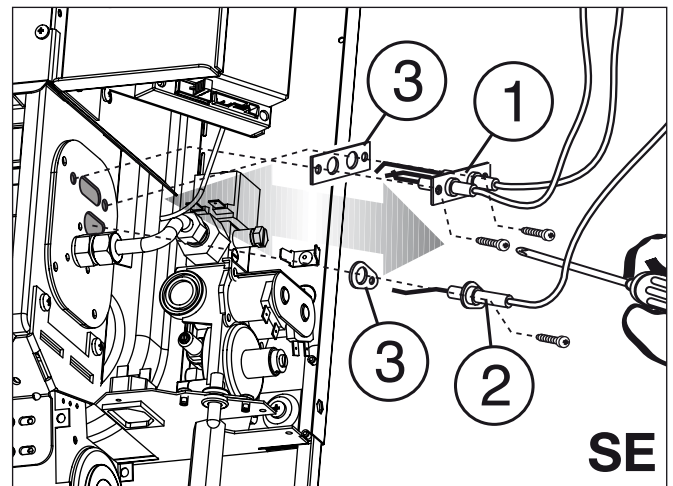
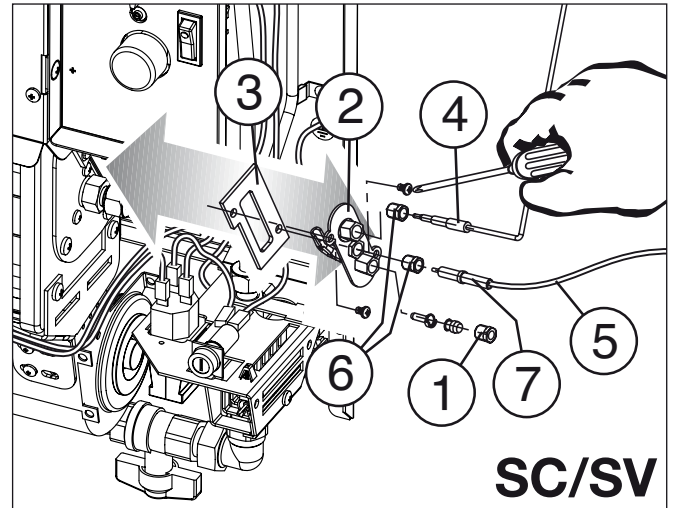

**!** If you need to replace any parts (pcb's, valves, thermostats, pressure switches, fans, etc.) use only original spare parts supplied by the manufacturer.

### Convection fan

Remove and restore the fan as follows:

- remove the electrical connections on the fan motor;
- remove the earth connection on the motor;
- undo the four screws securing the fan mounts to the heater's back frame and extract it;
- install a new unit in reverse order: first install the mounts, including dampers, to the slots, then secure it to the frame and restore the electrical connections to prevent malfunctions (such as incorrect speeds or short circuits).

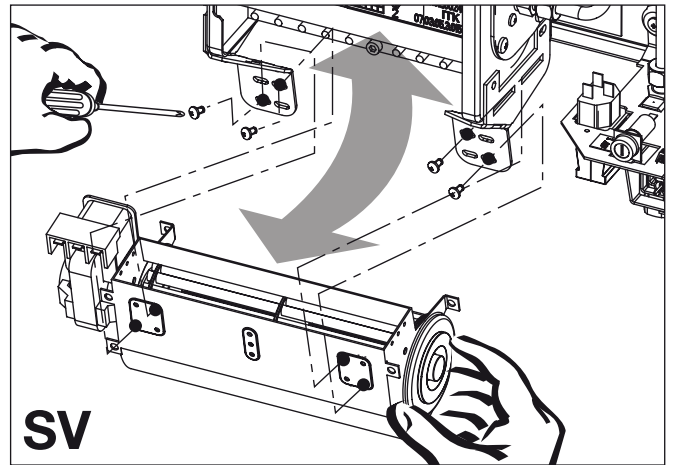

### Fuse burnt out

If the appliance does not turn on again following a short circuit, check the fuse as follows:

- undo the cap (1), and extract it.
- remove the fuse (2) and check it; if it is burnt or the filament is broken, replace it with another rapid fuse: 1A-250 V.

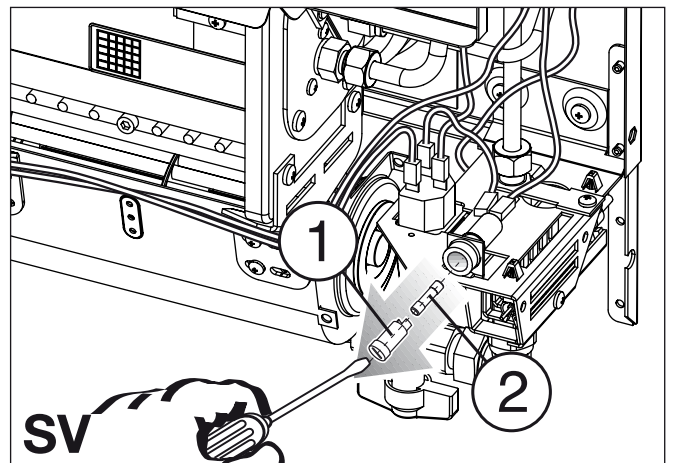

### Electrode

Remove and restore the ignition electrode as follows:

- disconnect the high voltage cable from the electrode connector
- undo the collar (6) and extract the electrode (7);
- fit a new electrode in reverse order; it will only fit in one position;
- take care not to damage the ceramic insulation.

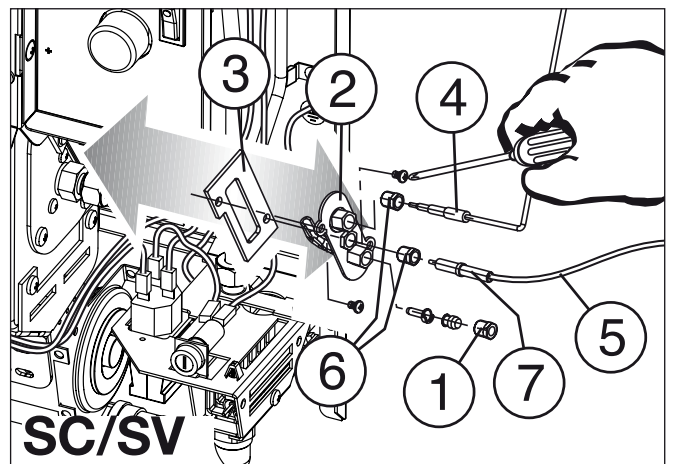

### Controller board

To remove and restore the controller board (1):

- squeeze the snap spacers to release the board;
- remove the connectors from their plugs;
- replace the board and replace the cables as before.

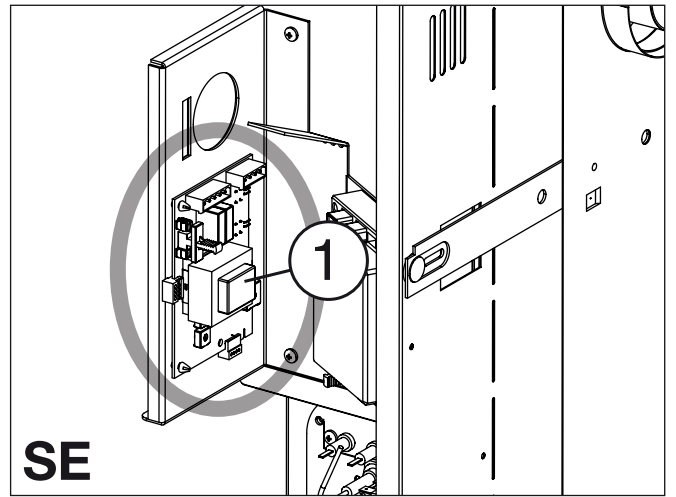

### Flame controller board

To remove and restore the flame controller board (1):

- undo the screws securing the board and take it off its mount;
- remove the connectors from their plugs;
- replace the board and replace the cables as before.

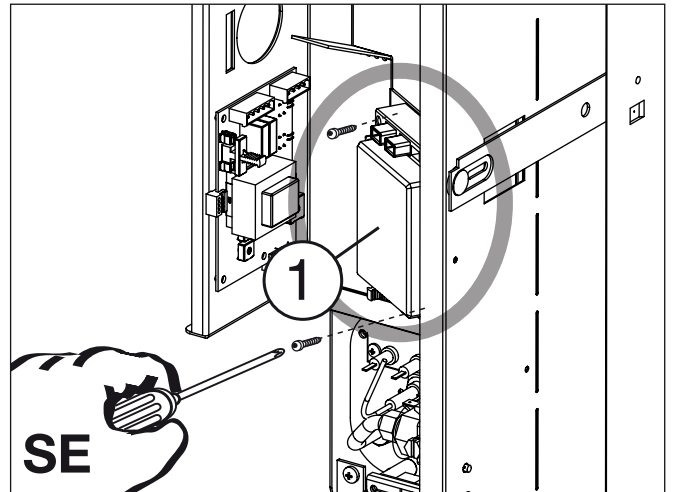

### Room thermostat sensor

To remove and restore the sensor (1):

- disconnect the faston connectors from their clips;
- release the sensor from its bracket;
- replace the part and fit the new one in reverse order.

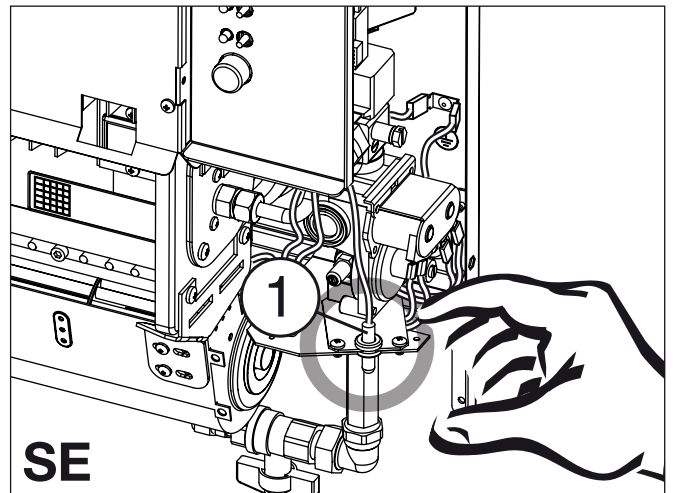

### Fuse burnt out

If the appliance does not turn on again following a short circuit, check the fuse as follows:

- carefully detach the outer cap (1);
- remove the fuse (2) and check it; if it is burnt or the filament is broken, replace it with another rapid fuse: 1A-250 V.

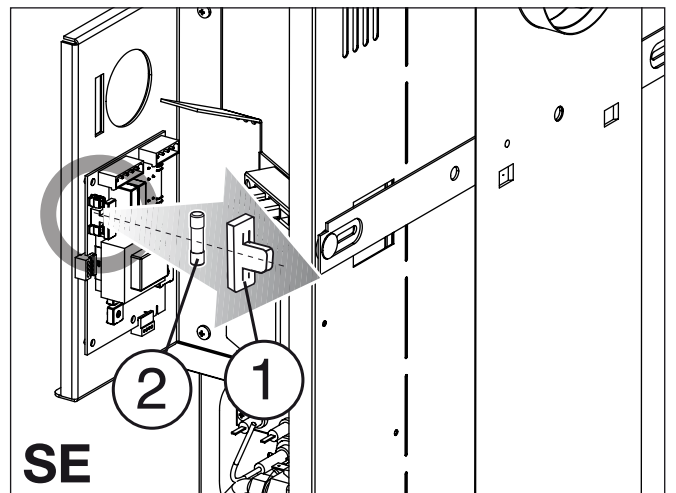

### Electrodes

To remove and restore the ignition electrode (1) or detector electrode (2):

- detach the electrode high voltage and ionisation cables from the flame control board, undo the screws and extract the electrode assembly;
- fit new ones in reverse order and replace the gaskets (3); the electrodes will only fit in one way;
- take care not to damage the electrodes' ceramic insulation and reconnect the cables to the board as before;

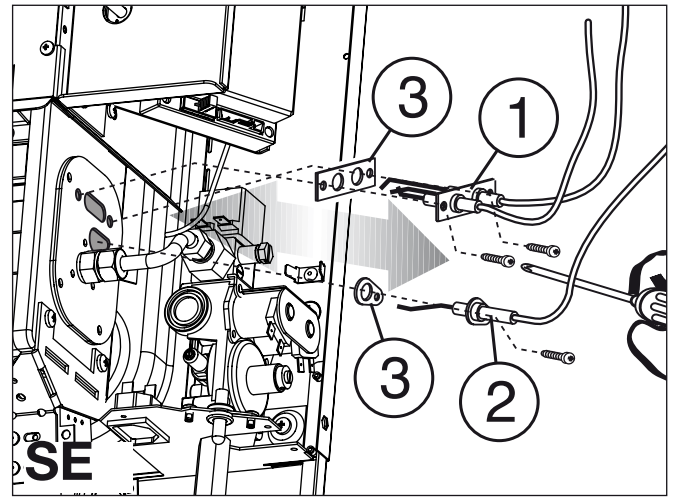

### Convection fan

Remove and restore the fan as follows:

- remove the electrical connections on the fan motor;
- remove the earth connection on the motor;
- undo the four screws securing the fan mounts to the heater's back frame and extract it;
- install a new unit in reverse order: first install the mounts, including dampers, to the slots, then secure it to the frame and restore the electrical connections to prevent malfunctions (such as incorrect speeds or short circuits).

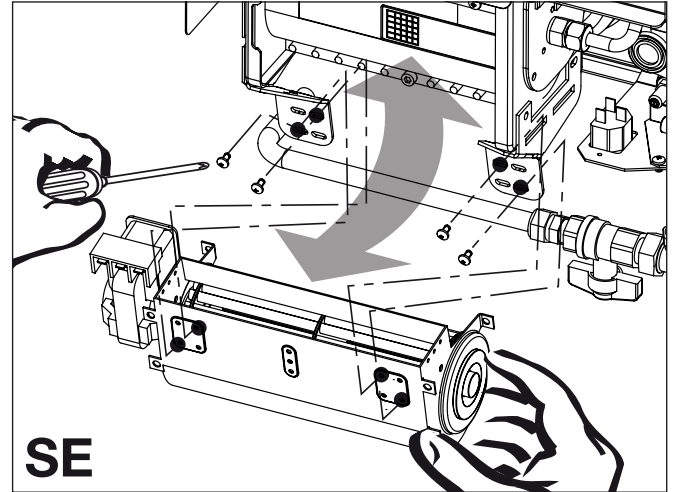

### White-Rodgers gas valve windings

Remove and restore the windings as follows:

- undo the two screws securing the bracket locking the windings (1) to the valve (2) and remove it;
  - extract the faulty winding with care;
  - fit the new winding and connect its plug (3) to the socket;
- 4 - Restore the bracket (4) to secure the windings.

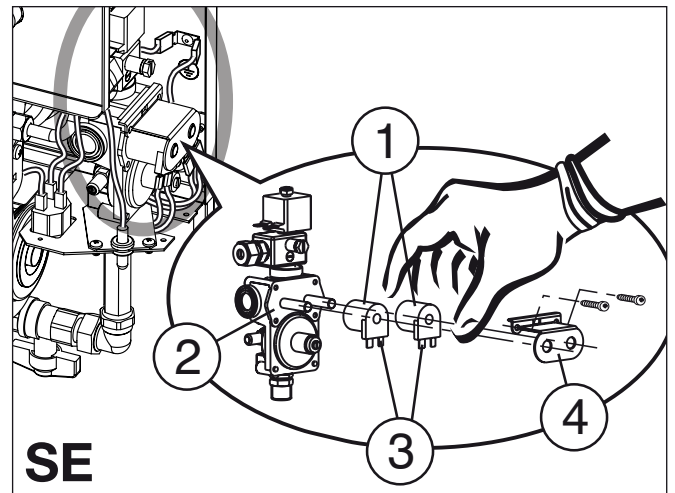

### Trigas modulator windings

Remove and restore the winding as follows:

- undo the electrical connections
- undo the nut (1) securing the winding (2) to the valve (3) and remove it;
- extract the faulty winding with care;
- fit the new winding in the right position;
- restore the electrical connections.

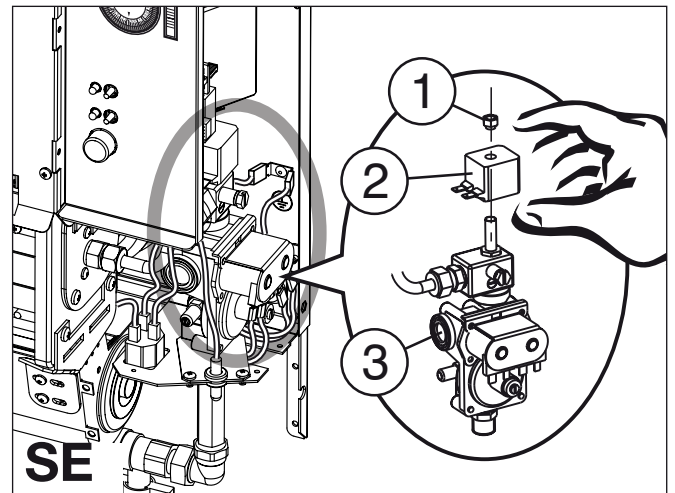

#### Convection fan thermostat

To remove and restore the thermostat (3):

- remove the thermostat bracket (1) by undoing the screw (2);
- disconnect the thermostat's electrical connectors;
- restore the thermostat in reverse order;

The thermostat runs the convection fan when the intake air reaches 45°C.



**Make sure to fit a thermostat with the correct calibration.**

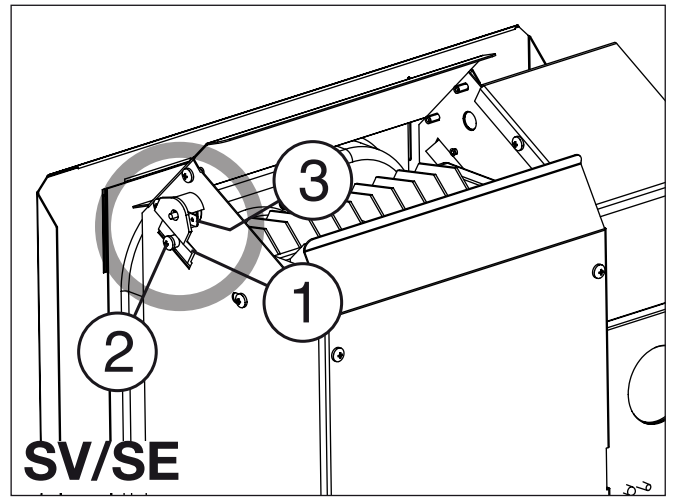

#### Safety thermostat (manual re-arm)

To remove and restore the thermostat (3):

- to facilitate access to the thermostat, take off the cover (4) by undoing its screws.
- remove the thermostat bracket (1) by undoing the screw (2);
- disconnect the thermostat's electrical connectors;
- restore the thermostat in reverse order;

The safety thermostat trips when the convection fan is not running properly, the appliance is overheating, or the output air is hotter than 107 °C, and turns off the burner, closes the gas valve and shuts the appliance down.

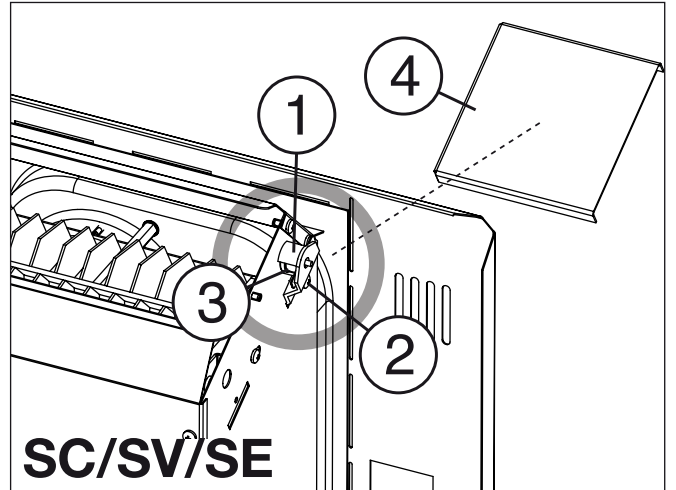

### *Removing the jacket*

- Remove the tray (3).
- Undo the screws (2) securing the jacket.
- Remove the external jacket (1) by lifting it completely off.

### *Restoring the jacket*

- Fit it against the edge of the frame, slide the front of the jacket onto the front of the frame and push it fully home.
- Hold it in place and secure it to the heater with the screw (2).
- Restore the tray (3).

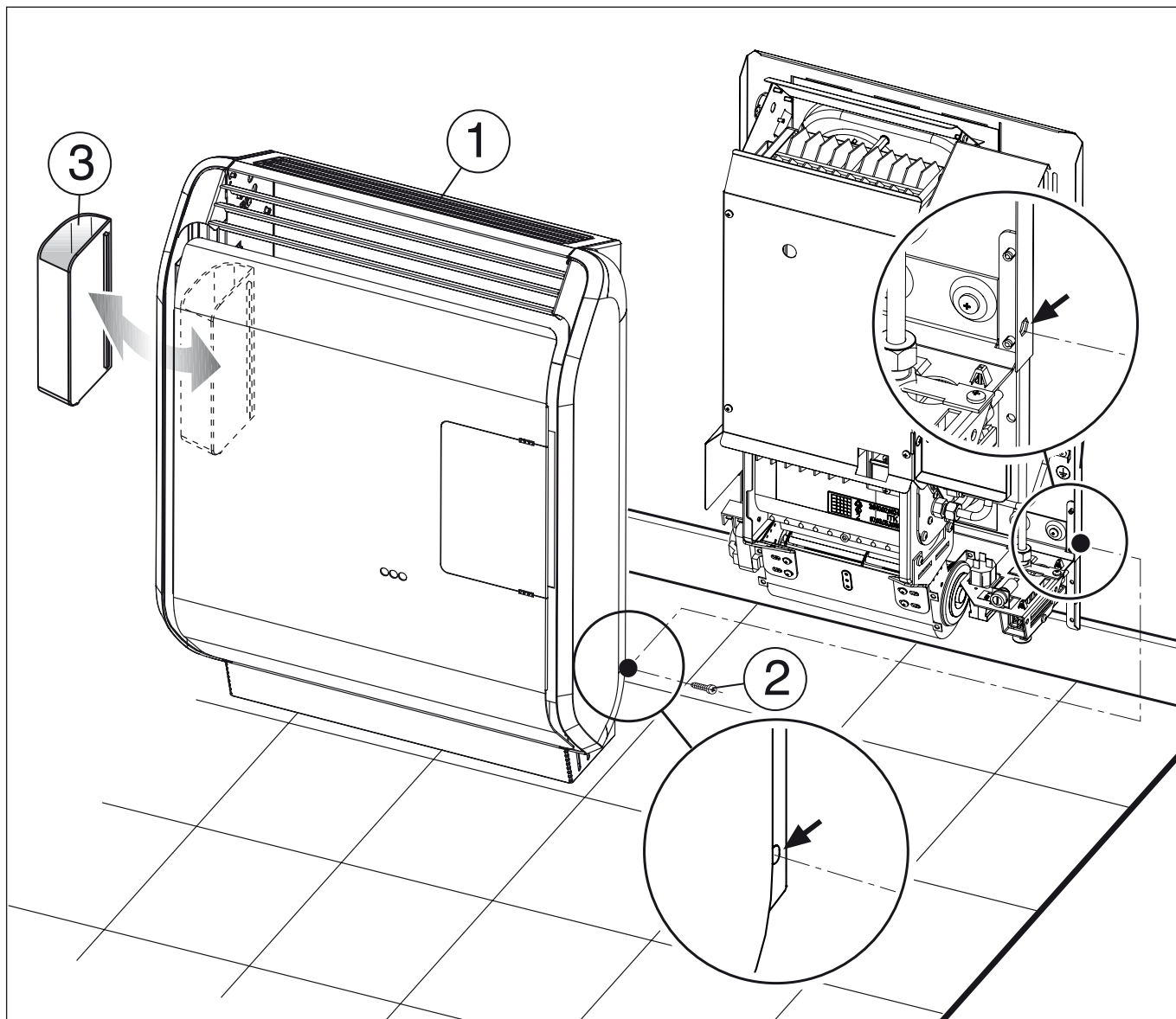

# SC/SV: TROUBLESHOOTING

FAULT	CAUSE	SOLUTION
The room thermostat is not working	Thermostat knob needs adjustment	Adjustment - turn towards 1 to decrease - turn towards 7 to increase
	Improperly positioned heater	Change installation position
	Top/bottom grille obstructed	Clear obstruction
	Thermostat bulb dislodged	Reposition
	Room thermostat faulty	Replace thermostat with gas valve
No ignition spark	Ignition electrode / cable: - defective - grounded - improperly connected	Check / replace
	Ignition knob not fully pushed in or not turned properly	Set knob correctly
	Ignition failure	Replace ignition unit with gas valve
The burner goes out while the heater is running	Intake/discharge pipes improperly installed	Check / restore - length of pipes - tight connection between appliance and pipes
	Inadequate or fluctuating gas pressure	Check / adjust gas
The appliance is not heating adequately	Selector knob set to pilot	Set to burner
	Thermostat on low setting	Set room thermostat to 7
	Improper injector/gas pressure	Check / adjust gas / replace injector
	Appliance not powerful enough for the room	Replace with a more powerful model
The fan does not run	Mains power disconnected	Check
	Air temperature less than 50°C	Check
	Ignition/control set to MIN	Switch to MAX
	Motor faulty	Replace
The hot air flow is reduced	Tangential fan failure	Replace
	Intake/outlet grille obstructed	Verify / Release
The fan does not change speed. The burner does not change its power setting.	Switch faulty	Check / replace

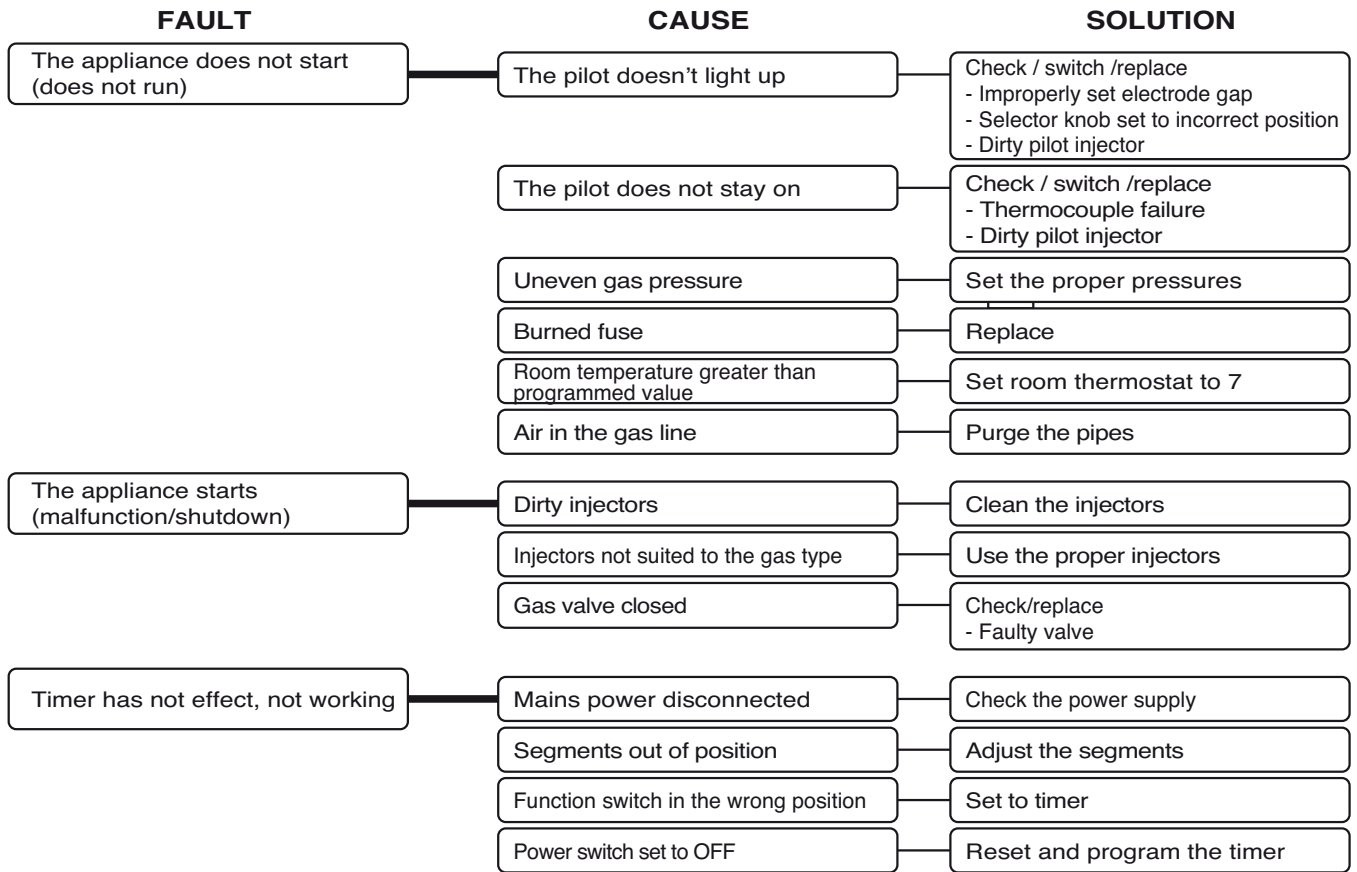

## SE: TROUBLESHOOTING

FAULT	CAUSE	SOLUTION
The room thermostat does not trip	Adjust thermostat knob	Adjust the thermostat knob: - turn towards 7 to increase - turn towards 1 to decrease
	Improperly positioned heater	Change appliance position
	Top/bottom grille obstructed	Clean / Free
	Thermostat bulb dislodged	Reposition
	Room thermostat faulty	Replace
No spark at ignition	Ignition electrode/detection unit faulty, earthed or badly connected	Check / replace
	Flame controller board faulty	Check / replace
The burner goes out while the heater is running	Inadequate or fluctuating gas pressure	Check/adjust the gas
	Intake and discharge pipes fitted badly	Check / restore - length of pipes - tight connection between appliance and pipes
The appliance is not heating adequately	Switch set to MIN	Switch to MAX
	Improper injector/gas pressure	Check and regulate the gas / replace
	Appliance not powerful enough for the room	Replace the appliance with a more powerful one
The fan does not run	Air temperature less than 50°C	Check / wait for heating to start
	Switch set to MIN	Switch to MAX
	Motor faulty	Replace
The hot air flow is reduced	Tangential fan failure	Replace
	Intake/outlet grilles obstructed	Clear obstruction
The burner does not change its power setting.	Switch faulty	Replace

FAULT	CAUSE	REMEDY
The appliance does not start	Power supply disconnected	Check
	Incorrect gas pressure	Set correct pressures
	Thermostat fails to engage	Adjust the thermostat
	Burnt-out fuse	Replace
	Control board faulty	Replace
	High room temperature	Room thermostat set too high.
	Air in gas pipes	Bleed
The appliance fails to start (appliance not working properly / blocked)	Incorrect ignition electrode distance	Reset the correct distance
	Nozzles dirty	Clean nozzles
	Installed nozzles not suitable for gas used	Fit right nozzles
	Control board faulty	Replace
	Gas valve closed	Check / Replace: - Safety thermostat tripped (tang. fan or faulty thermostat, gas setting) - Valve faulty
The timer does not engage or does not work	Wrong programming of segments	Adjust the segments
	Wrong function programming	Position on "clock"
	Interruption of power supply	Reset and re-programme the timer











**ITALKERO S.r.l.** . via Lumumba 2 . Zona Ind. Torrazzi . 41122 Modena . Italy . Tel +39 59 2550711 . FAX +39 059 4900500 . [www.italkero.it](http://www.italkero.it)

NOTA: Nel continuo perfezionamento del prodotto, le caratteristiche estetiche e dimensionali, i dati tecnici, gli equipaggiamenti e gli accessori, possono essere soggetti a variazione.

NOTE: Due to ongoing product upgrading, aesthetic and dimensional features, technical details, fittings and accessories could undergo changes and are not binding.

NOTE : En vue de l'amélioration continue des produits, les caractéristiques esthétiques et de taille, les données techniques, l'équipement et les accessoires peuvent être modifiés.

HINWEIS: Im Bestreben unsere Produkte kontinuierlich zu verbessern, können maßbezogene und ästhetische Eigenschaften, technische Daten, Ausrüstungen und Anlagen sowie Zubehörkomponenten Veränderungen unterworfen sein.